



# TX78XXM Series

## 0.5A Low Power LDO

<http://www.txsemi.com>

### Features

- Low voltage drop: 0.26V@100mA
- High input voltage: 15V
- Low temperature coefficient
- Large Output Current: >0.5A
- Low Quiescent Current: 2.0uA
- Output voltage accuracy: tolerance  $\pm 2\%$
- Built-in current limiter
- SOT23-3L and SOT89-3 packages

### Applications

- Battery-powered equipment
- Hand-Hold Equipment
- GRS Receivers
- Wireless LAN

### General Description

The TX78XXM series is a group of positive voltage output, three-pin regulators, it provides a high current even when the input/output voltage differential is small. Low power consumption and high accuracy is achieved through CMOS and laser trimming technologies.

The TX78XXM consists of a high-precision voltage reference, an error amplification circuit, and a current limited output driver. Load Transient response has improved in comparison to the existing series. SOT23-3L and SOT89-3 packages are available.

### Selection Table

Part No.	Output Voltage	Package	Marking
TX7818Mxx	1.8V	SOT23-3L SOT89-3	Refer to Marking rule
TX7828Mxx	2.8V		
TX7830Mxx	3.0V		
TX7833Mxx	3.3V		
TX7836Mxx	3.6V		
TX7840Mxx	4.0V		
TX7845Mxx	4.5V		
TX7850Mxx	5.0V		

### Order Information

TX78①②③④⑤

Designator	Symbol	Description
① ②	Integer	Output Voltage(1.8~5.0V)
③	M	Standard
④	M	Package: SOT23-3L
	P	Package: SOT89-3
⑤	R	RoHS / Pb Free
	G	Halogen Free

Note: "①②" stands for output voltages. Other voltages can be specially customized



<http://www.txsemi.com>

# TX78XXM Series 0.5A Low Power LDO

## Block Diagram

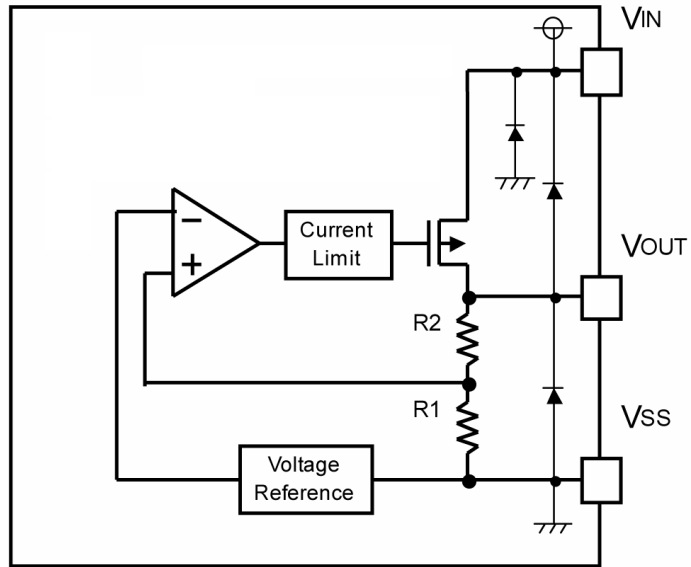



# TX78XXM Series

## 0.5A Low Power LDO

<http://www.txsemi.com>

### Pin Assignment

SOT23-3L(Top View)

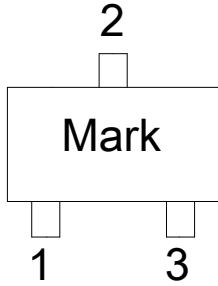

Table1: TX78XXMMR series (SOT23-3L PKG)

PIN NO.	PIN NAME	FUNCTION
1	GND	GND pin
2	VIN	Input voltage pin
3	VOUT	Output voltage pin

SOT89-3(Top View)

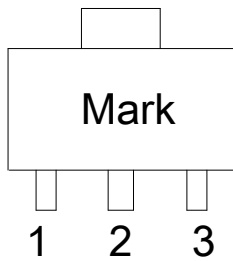

Table2: TX78XXMPR series (SOT89-3 PKG)

PIN NO.	PIN NAME	FUNCTION
1	GND	GND pin
2	VIN	Input voltage pin
3	VOUT	Output voltage pin



<http://www.txsemi.com>

# TX78XXM Series

## 0.5A Low Power LDO

### Marking Rule

#### (1) SOT23-3L

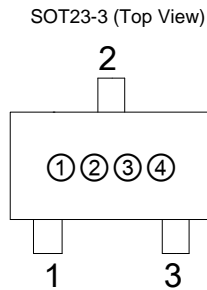

#### List of Product Name vs. Product Code

Product Name	Product Code		
	(1)	(2)	(3)
TX7812	S	A	A
TX7813	S	A	B
TX7814	S	A	C
TX7815	S	A	D
TX7816	S	A	E
TX7817	S	A	F
TX7818	S	A	G
TX7819	S	A	I
TX7820	S	A	J
TX7821	S	A	K
TX7822	S	A	L
TX7823	S	A	M
TX7824	S	A	N
TX7825	S	A	O
TX7826	S	A	P
TX7827	S	A	Q
TX7828	S	A	R
TX7829	S	A	T
TX7830	S	A	U
TX7831	S	A	V

Product Name	Product Code		
	(1)	(2)	(3)
TX7832	S	A	W
TX7833	S	A	X
TX7834	S	A	Y
TX7835	S	A	Z
TX7836	S	B	A
TX7837	S	B	B
TX7838	S	B	C
TX7839	S	B	D
TX7840	S	B	E
TX7841	S	B	F
TX7842	S	B	J
TX7843	S	B	H
TX7844	S	B	I
TX7845	S	B	J
TX7846	S	B	K
TX7847	S	B	L
TX7848	S	B	M
TX7849	S	B	N
TX7850	S	B	O

**NOTE: The last word is B.**



# TX78XXM Series

## 0.5A Low Power LDO

<http://www.txsemi.com>

### (2) SOT89

SOT89 (Top View)

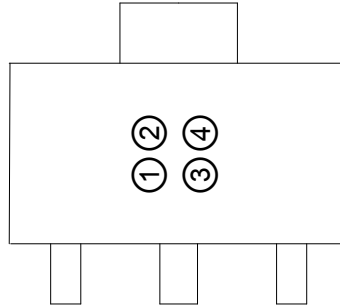

Product Code: E

Output Voltage Code:

Vout	Code	Vout	Code	Vout	Code
1.5V	1	2.7V	C	3.9V	O
1.6V	2	2.8V	D	4.0V	P
1.7V	3	2.9V	E	4.1V	Q
1.8V	4	3.0V	F	4.2V	R
1.9V	5	3.1V	G	4.3V	S
2.0V	6	3.2V	H	4.4V	T
2.1V	7	3.3V	I	4.5V	U
2.2V	8	3.4V	J	4.6V	V
2.3V	9	3.5V	K	4.7V	W
2.4V	0	3.6V	L	4.8V	X
2.5V	A	3.7V	M	4.9V	Y
2.6V	B	3.8V	N	5.0V	Z

Data Code: XX

Note: The last two of them are based on the time of this product which is the first time into production, and the third is the launch of this product, it can be in 1 ~ 9, which is expressed in "0" in October, in November with an "A", in December with "B"; the fourth is of the launch of the product, such as expressed in "0" in 2010, in "3" in 2013. For example: EZ81 represents TX7850PR product is first put into production in August in 2011.



# TX78XXM Series

## 0.5A Low Power LDO

<http://www.txsemi.com>

### Absolute Maximum Ratings

Supply Voltage .....3.5V to 18V      Storage Temperature .....-40°C to 125°C

Operating Temperature .....-40°C to 85°C

Note: These are stress ratings only. Stresses exceeding the range specified under "Absolute Maximum Ratings" may cause substantial damage to the device. Functional operation of this device at other conditions beyond those listed in the specification is not implied and prolonged exposure to extreme conditions may affect device reliability.

### Thermal Information

Symbol	Parameter	Package	Max.	Unit
$\theta_{JA}$	Thermal Resistance (Junction to Ambient) (Assume no ambient airflow, no heat sink)	SOT89	200	°C/W
		SOT23-3	250	°C/W
		SOT23-5	250	°C/W
$P_D$	Power Dissipation	SOT89	0.50	W
		SOT23-3	0.20	W
		SOT23-5	0.20	W

Note:  $P_D$  is measured at  $T_a = 25^\circ\text{C}$

### Electrical Characteristics

TX78XXM for any output voltage

( $T_a = 25^\circ\text{C}$ )

Parameter	Symbol	Conditions	Min.	Typ.	Max.	Unit
Output Voltage	$V_{out}$	$V_{in} = V_{out} + 1V$ $1.0\text{mA} \leq I_{out} \leq 30\text{mA}$	$V_{out} \times 0.98$	--	$V_{out} \times 1.02$	V
Output Current	$I_{out}$	$V_{in} - V_{out} = 1V$	--	500	--	mA
Low dropout	$V_{dif}$	Refer to the next table				
Line Regulation	$\frac{\Delta V_{OUT}}{\Delta V_{IN} \times V_{OUT}}$	$1.6V \leq V_{in} \leq 8V$ $I_{out} = 100\text{mA}$	--	0.05	0.2	%/V
Load Regulation	$\Delta V_{out}$	$V_{in} = V_{out} + 1V$ $1.0\text{mA} \leq I_{out} \leq 100\text{mA}$	--	12	30	mV
Output voltage Temperature Coefficiency	$\frac{\Delta V_{OUT}}{\Delta T_a}$	$I_{out} = 30\text{mA}$ $0^\circ\text{C} \leq T_a \leq 70^\circ\text{C}$	--	$\pm 100$	--	Ppm/°C
PSRR	PSRR	$F = 1\text{KHz}$ $V_{in} = V_{out} + 1V$	--	40	--	dB
Supply Current	$I_{ss1}$	--	--	1	2	uA
Input Voltage	$V_{in}$	--	3.5	--	15	V



## **TX78XXM Series**

### **0.5A Low Power LDO**

<http://www.txsemi.com>

Electrical Characteristics by Output Voltage:

Output Voltage Vout(V)	Differential Input Feedback Vdif (V)		
	Conditions	Typ.	Max.
2.0 < Vout ≤ 2.8	Iout=80 mA	0.4	0.6
2.8 < Vout ≤ 4.0	Iout=100 mA	0.26	0.46
4.0 < Vout ≤ 5.0		0.26	0.42
2.8 < Vout ≤ 4.0	Iout=200 mA	0.53	0.82
4.0 < Vout ≤ 5.0		0.42	0.76
3.0 < Vout ≤ 4.0	Iout=500 mA	1.5	1.8
4.0 < Vout ≤ 5.0		1.2	1.5



# TX78XXM Series 0.5A Low Power LDO

<http://www.txsemi.com>

## Typical Application

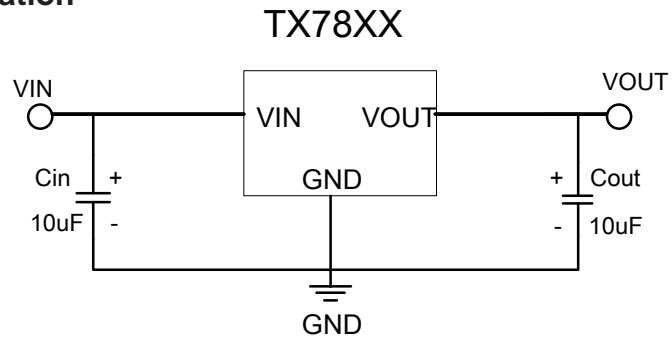

Note1:  $C_{in}=C_{out}=10\mu F$ . (10 $\mu F$  Electrolytic capacitor is recommended).

Note2: If the input and output capacitors are ceramic, add a resistor at the input, as follows.





<http://www.txsemi.com>

# TX78XXM Series 0.5A Low Power LDO

## Typical Performance Characteristics

(1) Output Voltage vs Input voltage

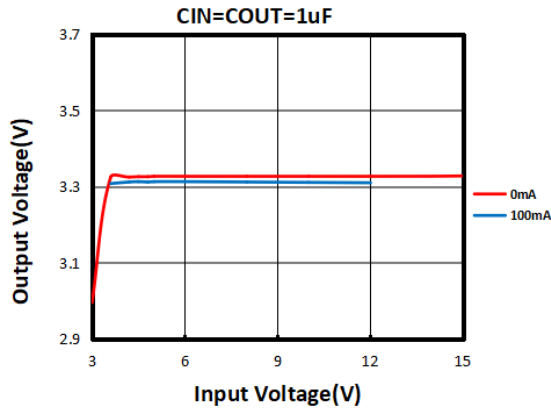

(2) Output Voltage vs Output Current

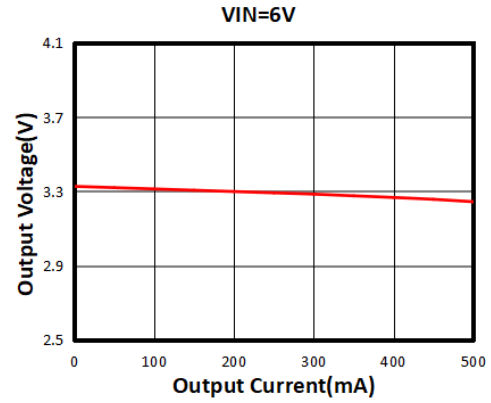

(3) Input Transient Response

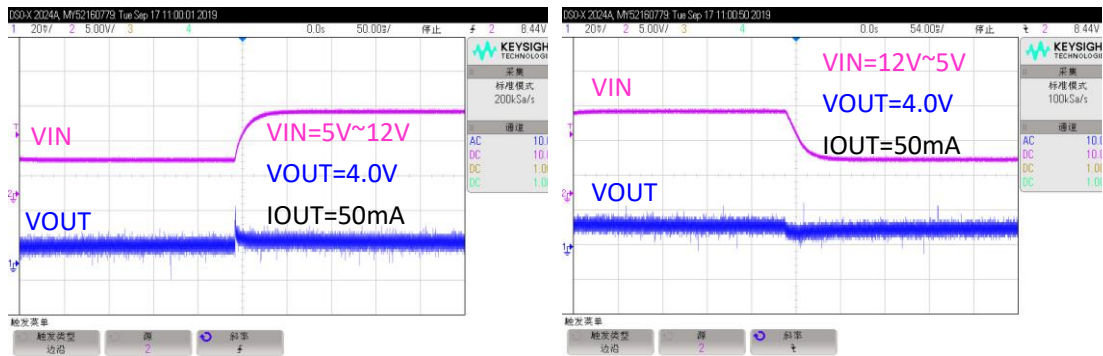

(4) Load Transient Response

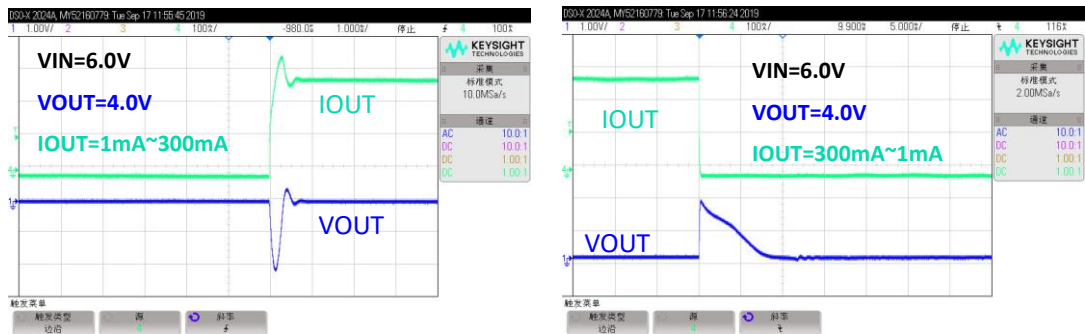



<http://www.txsemi.com>

## TX78XXM Series 0.5A Low Power LDO

### Package Information 3-pin SOT89-3 Outline Dimensions

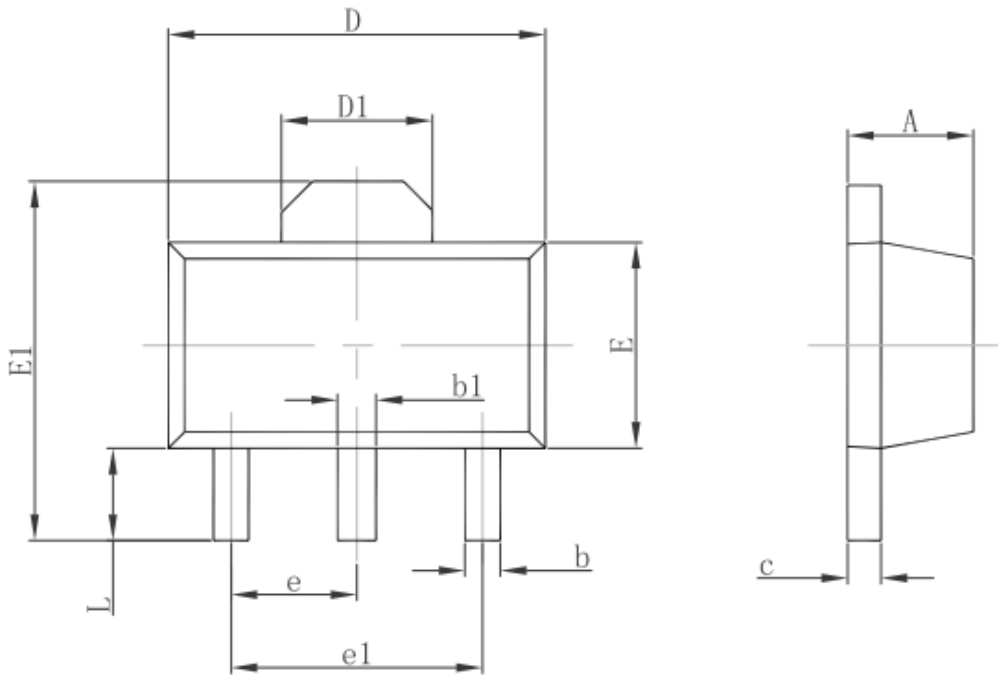

Symbol	Dimensions In Millimeters		Dimensions In Inches	
	Min.	Max.	Min.	Max.
A	1.400	1.600	0.055	0.063
b	0.320	0.520	0.013	0.020
b1	0.400	0.580	0.016	0.023
c	0.350	0.440	0.014	0.017
D	4.400	4.600	0.173	0.181
D1	1.550 REF.		0.061 REF.	
E	2.300	2.600	0.091	0.102
E1	3.940	4.250	0.155	0.167
e	1.500 TYP.		0.060 TYP.	
e1	3.000 TYP.		0.118 TYP.	
L	0.900	1.200	0.035	0.047



# TX78XXM Series 0.5A Low Power LDO

<http://www.txsemi.com>

## 3-pin SOT23-3 Outline Dimensions

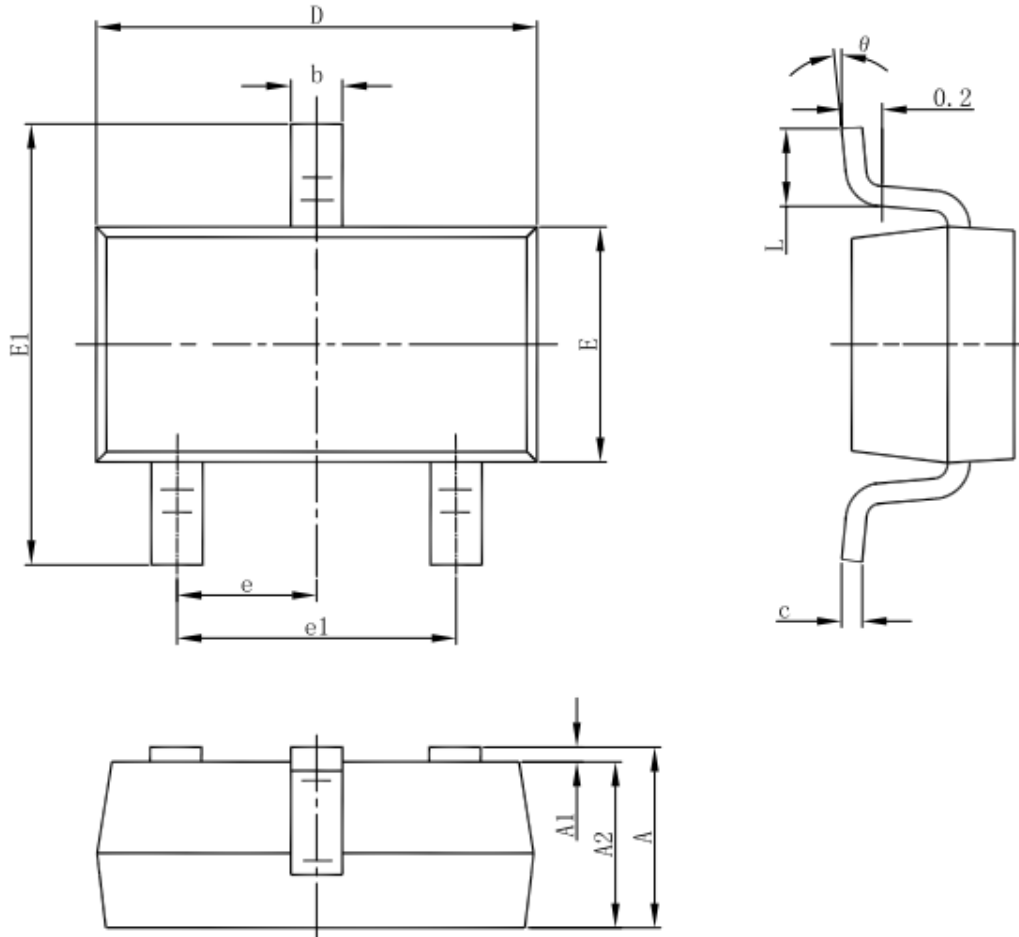

Symbol	Dimensions In Millimeters		Dimensions In Inches	
	Min	Max	Min	Max
A	1.050	1.250	0.041	0.049
A1	0.000	0.100	0.000	0.004
A2	1.050	1.150	0.041	0.045
b	0.300	0.500	0.012	0.020
c	0.100	0.200	0.004	0.008
D	2.820	3.020	0.111	0.119
E	1.500	1.700	0.059	0.067
E1	2.650	2.950	0.104	0.116
e	0.950(BSC)		0.037(BSC)	
e1	1.800	2.000	0.071	0.079
L	0.300	0.600	0.012	0.024
θ	0°	8°	0°	8°



<http://www.txsemi.com>

## ***TX78XXM Series*** ***0.5A Low Power LDO***

---

© Shanghai TX Electronics Sci-Tech Co., Ltd

TX cannot assume responsibility for use of any circuitry other than circuitry entirely embodied in a TX product. No circuit patent license, copyrights or other intellectual property rights are implied. TX reserves the right to make changes to their products or specifications without notice. Customers are advised to obtain the latest version of relevant information to verify, before placing orders, that information being relied on is current and complete.