



Features

- Built-in current sampling circuit
- Low standby current, low static operating current
- Integrated H-bridge drive circuit
- Built-in anti-common mode switching-on circuit
- Low on-resistance power MOSFET
- Maximum continuous output current: 2A@VDD=12V
- Maximum peak output current: 4A@T=0.2S, D=0.25, VDD>=6V
- Instantaneous withstand current: 7A@VDD=6V, about 10us
- On-chip thermal shut down(TSD) with hysteresis
- Anti-static grade: 3KV (HBM)

Typical application

- Toy motor drive with 2-4 AA / AAA dry cells;
- Toy motor drive with 2-6 Ni-H / Ni-Cd rechargeable batteries;
- Toy motor drive with 1-2 Lithium-ion battery

Description

TX861 provides an integrated brush DC motor drive solution for battery-powered toys, low-voltage or battery-powered motion control applications. The circuit integrates on-chip H-bridge drive circuit designed with N-channel and P-channel power MOSFETs and is suitable to drive a brushless DC motor or a stepper motor winding. It has the wider operational voltage range (from 2V to 12.0V), its maximum continuous output current is up to 2A, and its maximum peak output current is up to 4A. The series circuit powered by VCC and VDD separate, which VCC is logic and control power supply, VDD is power supply.

TX861 has on-chip temperature protection function. When the load current of the drive circuit is much larger than the maximum continuous current of the circuit, the junction temperature of the circuit will

be increased rapidly. Once the set value (150°C) is exceeded, the internal circuit will be closed immediately Off the output power tube, cut off the load current, to avoid the temperature continued to rise caused by plastic packaging smoke, fire and other security risks. Built-in temperature hysteresis circuit to ensure the circuit is restored to a safe temperature before allowing the circuit to be re-controlled.

TX861 set a separate current sampling output pin, sampling output current sampling ratio of 1000:1. The output sampling current for MCU analysis or control the external circuits to control the output current.

Pin Assignment

1	VCC	-	Power supply of logic control circuit
2	INA	I	Forward rotation logic input
3	INB	I	Backward rotation logic input
4	IREF	O	Current sampling output
5	OUTB	O	Backward rotation output
6	VDD	-	Power supply
7	GND	-	Ground
8	OUTA	O	Forward rotation output

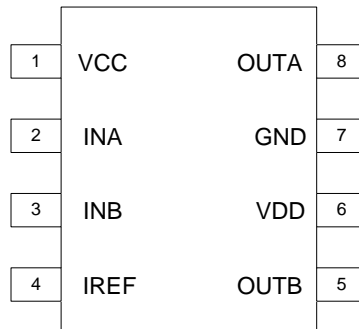

Logic Truth Table

INA	INB	OA	OB	Function
L	L	Z	Z	Stop (Standby)
H	L	H	L	Forward rotation
L	H	L	H	Backward rotation
H	H	L	L	Brake

Functional Block Diagram

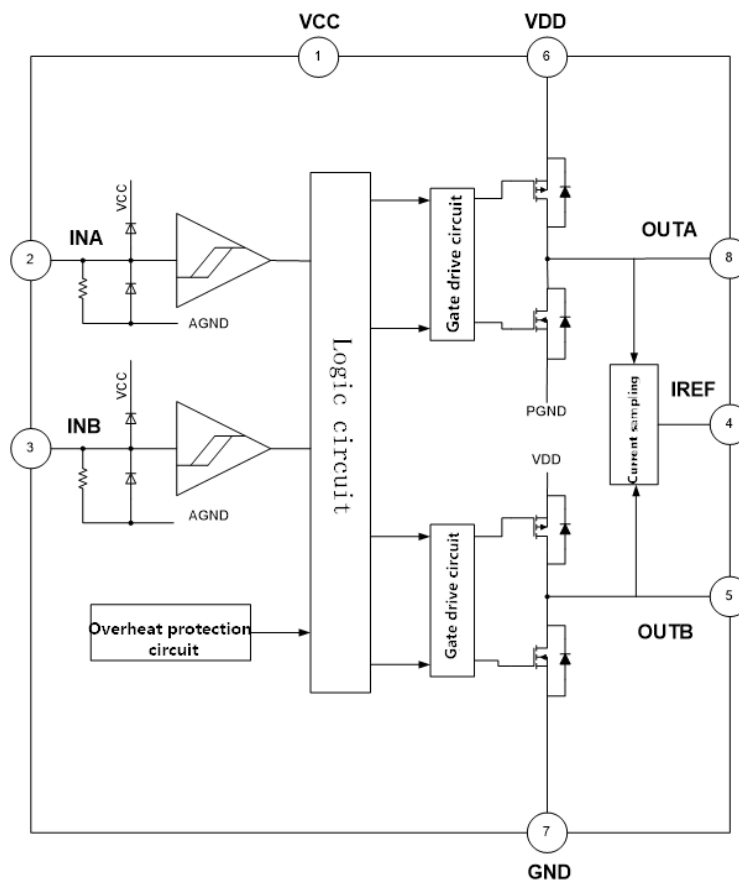



Absolute Maximum Ratings (TA=25°C)

Parameter	Symbol	Rating	Unit
Maximum logic and control supply voltage	VCC(MAX)	9	V
Maximum power supply voltage	VDD(MAX)	16	
Maximum peak output current	IOUT(PEAK)	4	A
Maximum power consumption	PD_MAX (Note1, 2)	ESOP-8 1.5	W
Junction-to-ambient thermal resistance	θ_{JAS}	ESOP-8 84	°C/W
Operating temperature range	T _{OPR}	-20~+85	°C
Junction temperature	T _{J,MAX}	150	°C
Storage temperature	T _{STG}	-55~+150	°C
Welding temperature	T _{LED}	260°C, 10s	
ESD (Note3)		3000	V

Note: (1)、The maximum power dissipation formula for different ambient temperatures is : $PD = (150^{\circ}C - TA) / \theta_{JA}$

TA is the ambient temperature of the operating circuit, θ_{JA} is the package thermal resistance
150°C represents the maximum operating junction temperature of the circuit.

(2)、The method of calculating power dissipation: $P = I^2 * R$.

P is the circuit power consumption, I is the continuous output current, and R is the on-resistance of the circuit. Circuit power consumption P is less than the maximum power consumption PD.

(3)、Human body model, 100pF capacitor through the 1.5KΩ resistor discharge.

Recommended Operating Conditions (TA=25°C)

Parameter	Symbol	Min	Typ	Max	Unit
Logic and control supply voltage	VCC	2	3	6	V
Power supply voltage	VDD	3	6	12	V
Continuous output current	IOUT		2	2.6	A

Note: (1)、Logic and control supply power VCC are completely independent with the power supply. They can be powered separately. When the logic and control power supply VCC are powered down, the circuit will enter the standby mode.

(2)、The continuous output current test condition is: Circuit mounted on PCB test, ESOP8 package test board size 27mm * 27mm.



Electrical Characteristics (Ta=25°C, VCC=3V, VDD=6V, unless otherwise specified)

Parameter	Symbol	Conditions	Min	Typ	Max	Unit
Power supply parameters						
VCC Standby current	I _{VCCST}	INA=INB=L; V _{CC} =3V; V _{DD} =9V; with Output open	--	0	0.1	uA
VDD Standby current	I _{VDDST}		--	0	0.1	
VCC static supply current	I _{VCC}	INA=H or INB=H; with Output open	--	175	--	uA
VDD static supply current	I _{VDD}		--	45	--	
Input logic level						
Input high voltage	V _{INH}		2	--	--	V
Input low voltage	V _{INL}		--	--	0.8	
Input level hysteresis	V _{INHYS}		--	0.6	--	
Input high current	I _{INH}	V _{INH} =3V, V _{CC} =3V	--	300	--	uA
Input pull-down resistor	R _{IN}	V _{INH} =3V, V _{CC} =3V	--	10	--	KΩ
Power transistor on-resistance						
On-resistance	RON1	IO=±200mA V _{DD} =6V TA=25°C		0.3		Ω
		IO=±1A V _{DD} =6.5V TA=25°C		0.31		
Protection function parameters						
Thermal shutdown temperature point	TSD		--	150	--	°C
Thermal shutdown hysteresis	T _{SDHYS}		--	130	--	
Power MOSFET diode conduction characteristics						
PMOS body diode	V _{PD}	I=400mA, V _{CC} =3V, V _{DD} =INA=INB=0V		0.76		V
NMOS body diode	V _{ND}	I=-400mA, V _{CC} =V _{DD} =3V, INA=INB=0V		0.75		
Time parameter(VCC=VDD=5V)						
Output rise time	t _r	INB=GND, INA input 20KHZ PWM signal. OUTA to 100 ohm load to GND.		200		ns
Output fall time	t _f				58	
Input A delays the output A signal in the same direction	t _{rr}	INB=GND, INA input 20KHZ PWM signal. OUTA to 100 ohm load to GND.		528		
	t _{ff}			240		
Input A reverses the output B delay	t _{rf}	INB=5V, INA input 20KHZ PWM signal. OUTB to 100 ohm load to GND		242		
	t _{fr}			548		
Sampling current output						
Sampling output current	I _{REF}	V _{CC} =3V, V _{DD} =9V, I _o =0.5A		0.5		mA

1.The delay of input signal B to output B is the same as the delay of input signal A to output signal A in the above table.

2.The delay at the input B of the output A reverse signal is the same as the delay of the input A to the output B reverse signal in the above table.



Electrical characteristic curve

Sampling current curve with VCC (VDD = 12V)

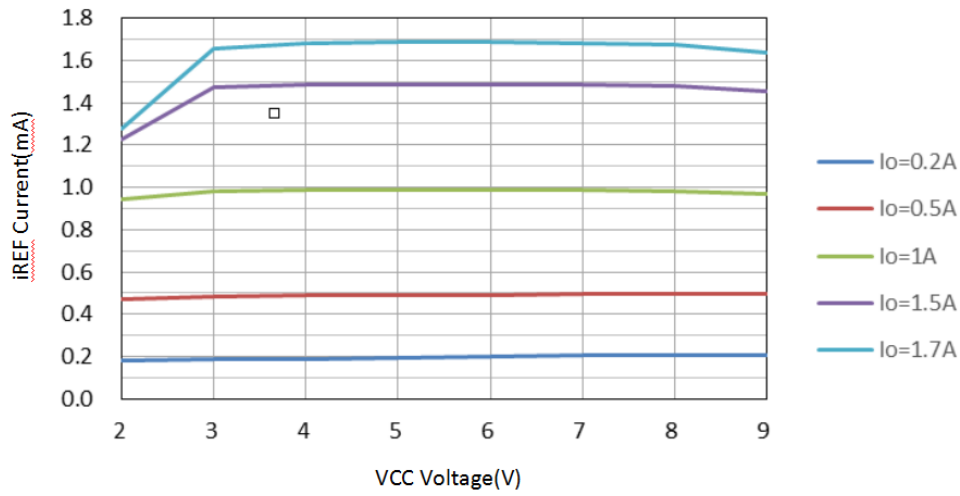

The sampling current varies with the VDD curve (VDD = 3V)

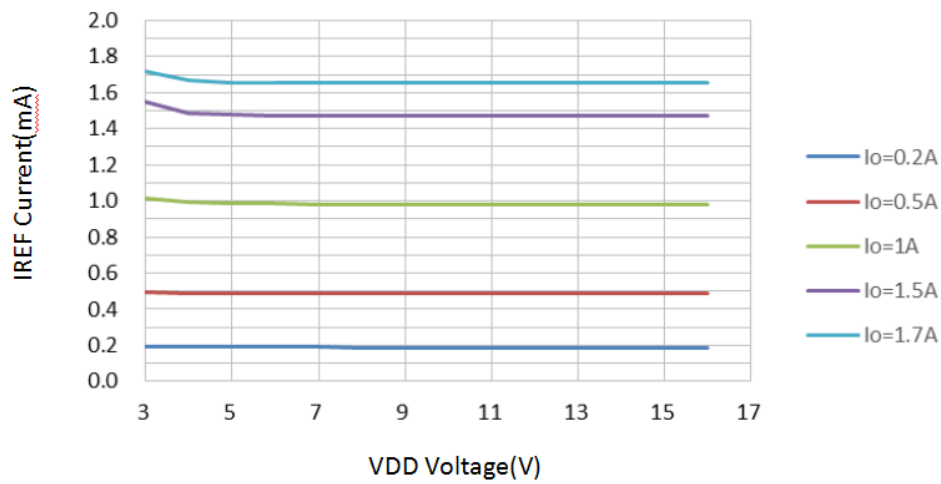

The sampling current varies with the Io curve (VCC = 3V, VDD = 9V)

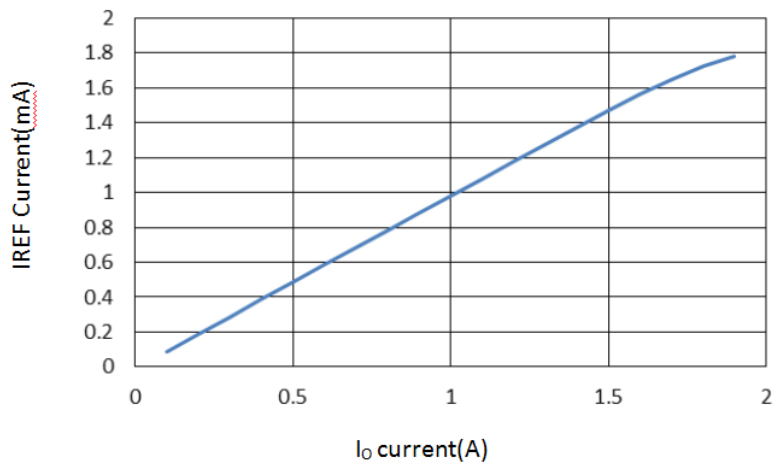



VCC quiescent current with voltage change curve

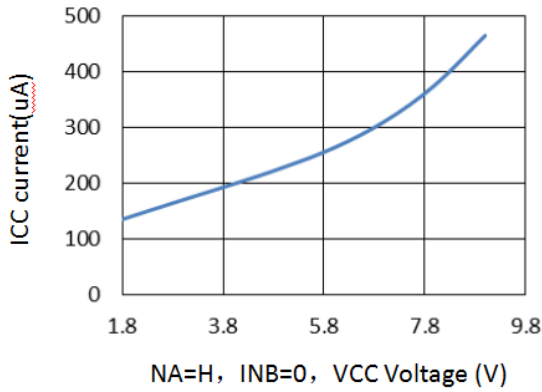

VDD quiescent current with voltage change curve

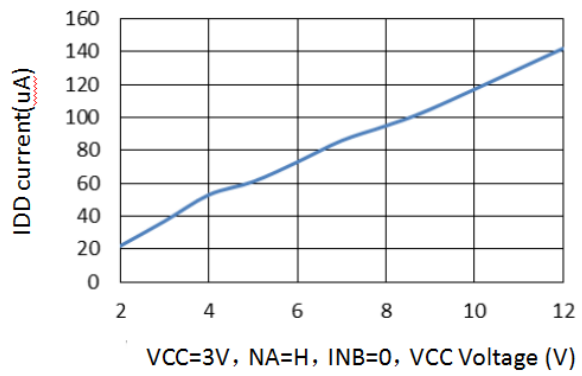

on-resistance of power MOSFET

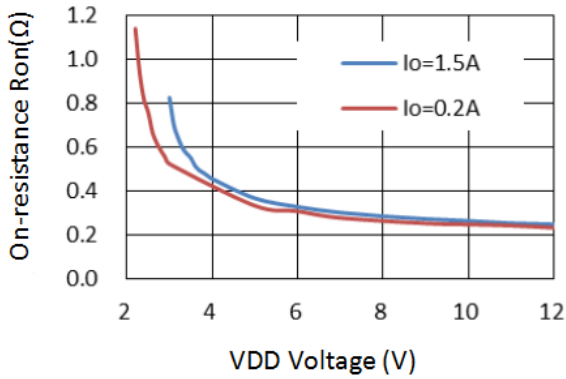

The logic input current varies with the voltage curve

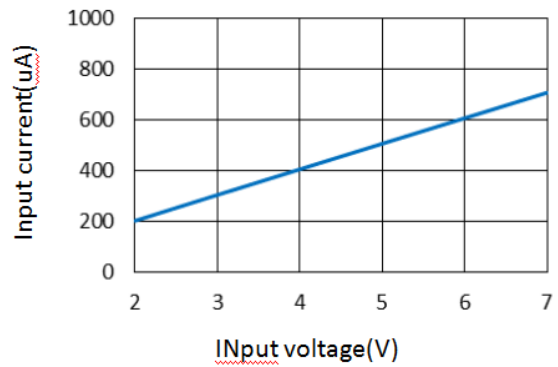

Logic high / low voltage with VCC curve

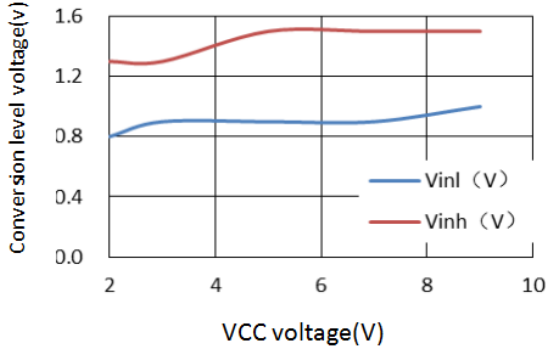

Power transistor diode conduction characteristics

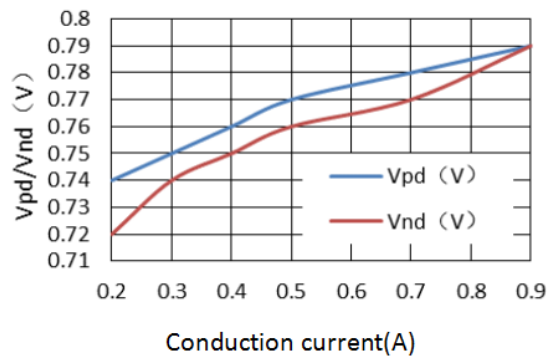

The continuous current varies with the VDD voltage

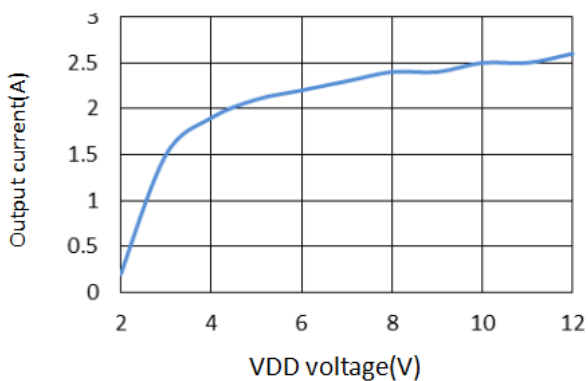



Testing schematic diagram

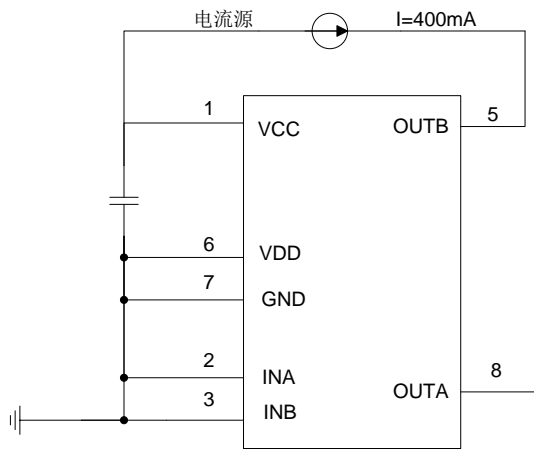

NMOS body diode conduction voltage test schematic

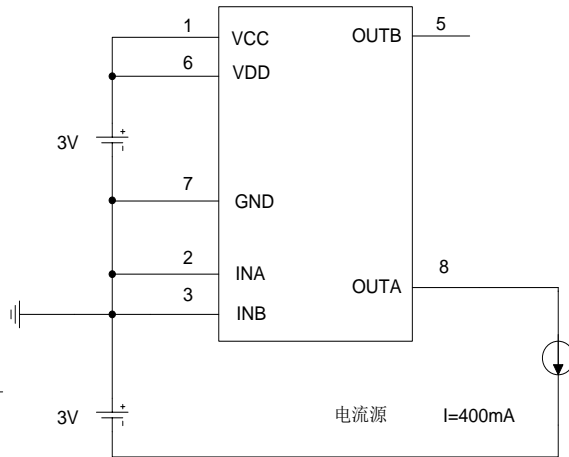

PMOS body diode conduction voltage test schematic

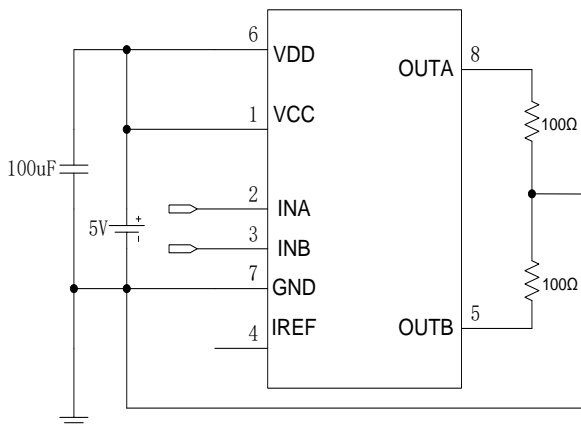

Time parameter test schematic

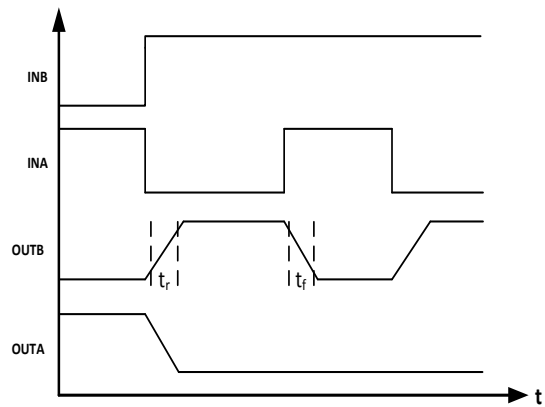

Time parameter definition 1

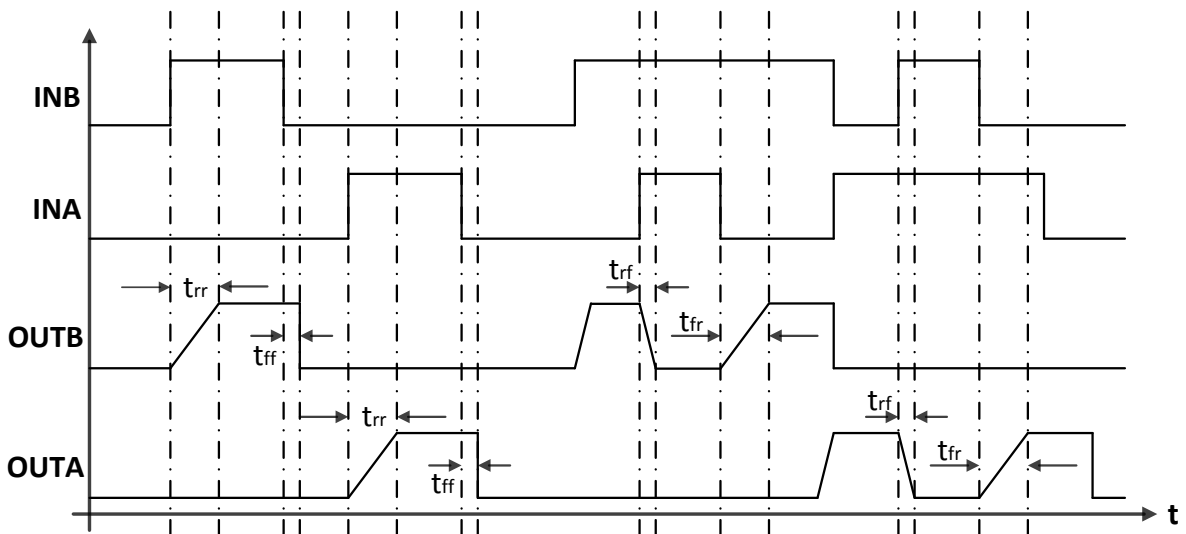

Time parameter definition 2



Typical application circuit

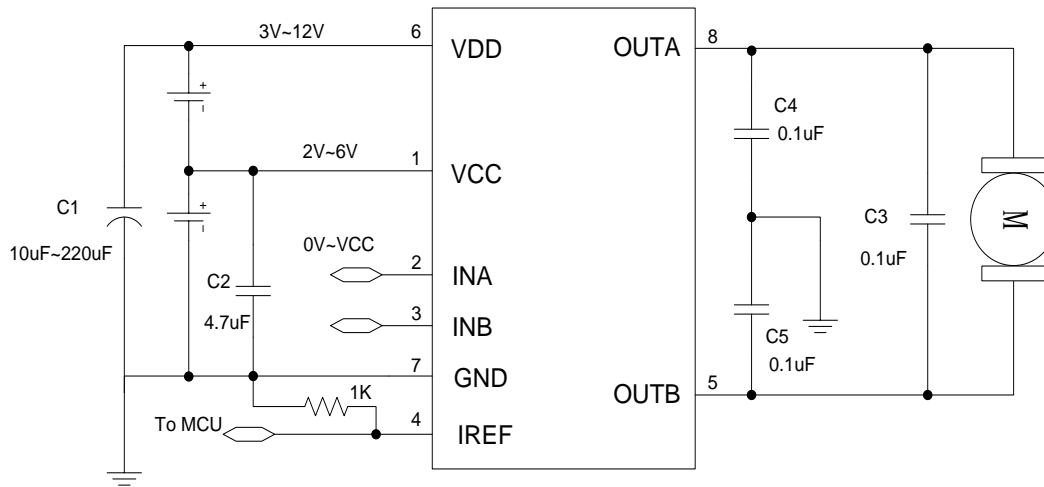

special attention items:

1. In Figure 1, the C1 capacitor is located as close as possible to the power supply VDD, and the C3/0.1uF capacitor is connected to the motor, not the PCB.
2. The capacitance of the power supply VDD decoupling capacitor (C1) in Figure 1 should be adjusted according to the specific application. The higher the VDD voltage, the greater the output peak current, the greater the value of C1, but the value of capacitor C1 is at least Need 10uF. It is recommended that capacitor C1 be 220uF under high voltage and high current application conditions.
3. Because the motor will cause great interference to the power supply during operation, the logic power supply VCC is preferably added with a capacitance C2 to the ground, it is recommended to be more than 1uF. In practical applications, it is not necessary to add a capacitor separately from the chip, and it can be used with other control chips (RX2, MCU, etc. are shared).
4. IREF pin is the current sampling pin, which is convenient for customers to add over-current protection function according to actual requirements, which can greatly improve the safety of the driver chip.
5. If you do not use IREF to take appropriate current limiting protection measures, when the peak current when the selected motor starts exceeds 5A, if the frequency of forward and reverse switching is too fast, that is, the motor does not turn normally, the direction is switched, the chip It may not be able to burn out because of TSD protection. If it is necessary to use this kind of motor, it is recommended that the MCU add delay control at the INA and INB input control terminals to mask the fast-switching signal. The delay should be at least 1s or longer, and the longer it is, the more secure it is. If the forward rotation is reversed, a better control method is to first stop the motor and then reverse the motor, that is, to stop the motor and switch the direction. This protects the motor and protects the driver chip.



Application Note

1、 Basic working mode

a) Standby mode

Standby mode is defined as $INA=INB=L$. All internal circuits, including drive power transistor are switched off and the circuit dissipates very low current. At the time, motor outputs OUTA and OUTB are in high impedance state.

b) Forward rotation mode

Forward rotation mode is defined as $INA=H, INB=L$. At this time, motor drive terminal OUTA outputs high level, motor drive terminal OUTB outputs low level, and motor drive current flows from OUTA into motor and from OUTB into ground. The rotation of motor at the time is defined as forward mode.

c) Backward rotation mode

Backward rotation mode is defined as $INA=L, INB=H$. At this time, motor drive terminal OUTB outputs high level, motor drive terminal OUTA outputs low level, and motor drive current flows from OUTB into motor and from OUTA into ground. The rotation of motor at the time is defined as backward rotation mode.

d) Brake mode

Brake mode is defined as $INA=H, INB=H$. At this time, motor drive terminals OUTA and OUTB both output high level, the energy stored in motor will be released rapidly from NMOS transistor at terminal OUTA or NMOS transistor at terminal OUTB, and motor will stop rotating in a short time. Please note that circuit will dissipates static power in brake mode.

e) PWM mode A

If input INA is PWM signal and $INB = 0$ or if input INB is PWM signal and $INA = 0$, then rotation speed of motor will be controlled by duty cycle of PWM signal. In this mode, motor drive circuit will be switched between switching-on and standby mode. In standby mode, all the power transistors are in off state, the energy stored in motor can only be released slowly from power MOSFET body diode. Note that rotation speed of motor cannot be precisely controlled by duty cycle of PWM signal as there is a high-impedance state in working mode. If frequency of PWM signal is too high, then the case that motor cannot be started would occur.

f) PWM mode B

If input INA is PWM signal and $INB = 1$ or if input INB is PWM signal and $INA = 1$, then rotation speed of motor will be controlled by duty cycle of PWM signal. In this mode, motor drive circuit output will be switched between switching-on and brake mode. In brake mode, the energy stored in motor will be released rapidly from low-side NMOS transistor.

Note that rotation speed of motor can be precisely by duty cycle of PWM signal as there is a brake state in working mode and the energy of motor can be released quickly. However, it must be noted that, if frequency of PWM signal is too low, the case that motor cannot be rotated continuously and smoothly due to entering brake mode would occur. To reduce noise of motor, it is recommended that frequency of PWM signal be between 10KHz and 50KHz.

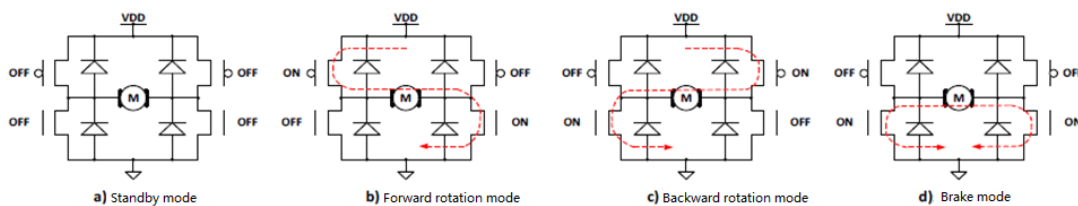

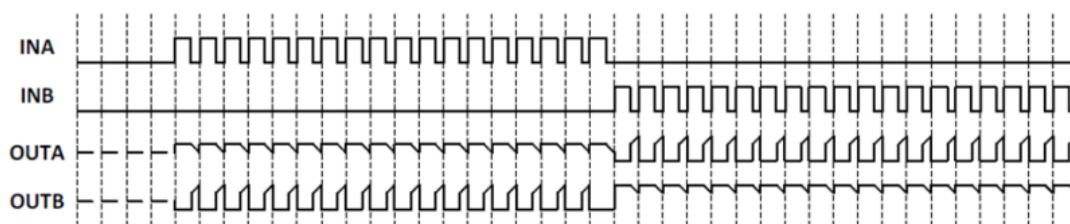

PWM mode A signal waveform diagram

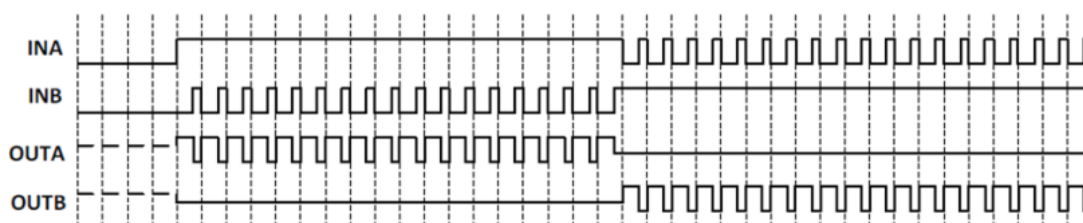

PWM mode B signal waveform diagram

2、 Anti-common mode switching-on circuit

In full-bridge drive circuit, the state where both the high-side PMOS power transistor and the low-side NMOS power transistor are switched on at the same time in half bridge is called the common-mode switching-on state. In the common-mode switching-on state there is a power-to-ground, transient, high current, which would cause an extra power loss, and, in extreme cases, would burn the circuit down. With built-in dead time, the common mode switching-on state can be avoided. The typical dead time is 300ns.

3、 Overheat protection circuit

If junction temperature of drive circuit exceeds a preset temperature (150 °C, typically), then TSD circuit starts to work. At this time, control circuit is forced to switch off all output power transistors, and drive circuit output gets into high-impedance state. TSD circuit is designed with thermal hysteresis. Only if junction temperature of drive circuit decrease to a preset temperature (130 °C, typically), can the circuit get back to normal operating condition.

4、 Maximum continuous power dissipation of drive circuit

The motor drive circuit series is designed with on-chip overheating protection circuit. Therefore, if drive circuit dissipates too much power, then the circuit will get into thermal shut down (TSD) mode and the motor won't operate normally in thermal shut down (TSD) mode. The formula of maximum continuous power consumption of drive circuit can be expressed as:

$$P_M = (150^\circ\text{C} - T_A) / \theta_{JA}$$

Where 150 °C is a preset temperature point for TSD circuit, T_A is an ambient temperature in °C, and θ_{JA} is a junction-to-ambient thermal resistance of circuit in °C/W.

Note that the maximum continuous power consumption of drive circuit is related with factors such as ambient temperature, package type, heat radiation design, but isn't related directly with internal on-resistance of circuit.

5、 Power dissipation of drive circuit

Internal on-resistance of power MOSFET transistor in motor drive circuit is the primary factor that



affects power dissipation of drive circuit. The formula of power dissipation of drive circuit can be expressed as

$$P_D = I_L^2 * R_{ON}$$

Where I_L is continuous output current and R_{ON} is power MOSFET on-resistance.

It should be noted that power MOSFET on-resistance will increase with increasing temperature and that, if maximum continuous output current and power dissipation of circuit are calculated, the temperature performance of internal on-resistance must be considered.

6、Maximum continuous output current of drive circuit

From maximum continuous power dissipation of drive circuit and power dissipation of drive circuit, maximum continuous output current of drive circuit can be obtained. Formula is as follows.

$$I_L = \sqrt{(150 - T_A) / (\theta_{JA} * R_{ONT})}$$

Where R_{ONT} is power MOSFET on-resistance with the temperature performance considered.

Note that maximum continuous output current of drive circuit is related to factors such as ambient temperature, package type, heat radiation design, and power MOSFET on-resistance.

7、Selection of the motor on-resistance

It can be seen from the above analysis that maximum continuous power dissipation of motor drive circuit is limited. If the motor on-resistance driven by circuit is very low, and if blocked motor current exceeds maximum continuous output current which can be taken by motor drive circuit too much, then motor drive circuit will enter overheating shut down state easily, and toy car will jitter in running or going back and forth repeatedly. Therefore, when motor drive circuit is chosen, it is necessary to consider the motor on-resistance.

Special notes

1.Reversal between power supply and ground

Reversal or reverse connection between power supply and ground will cause the circuit to damage, and, when it is serious, cause a plastic package to smoke. It is considerable to connect a power Schottky diode in series between the circuit positive terminal VDD and the battery positive terminal in order to avoid circuit damage due to battery reversal. Maximum continuous current of power Schottky diode must be greater than the continuous current with motor blocked; otherwise the Schottky diode will damage owing to overheating. Reverse breakdown voltage of power Schottky diode must be greater than maximum supply voltage. If the reverse breakdown voltage is too low, then the Schottky diode, when battery is reversed, would be broken down, thus resulting in being burnt down.

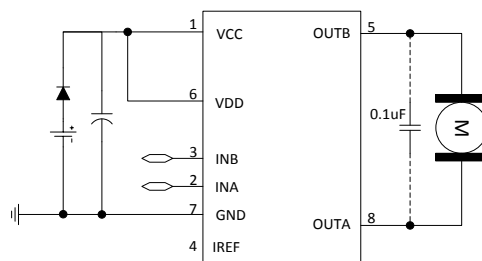



2、 Power supply VDD-to-ground decoupling capacitor C1

Drive circuit requires that power supply VDD-to-ground decoupling capacitor C1 (refer to Fig. 1) has mainly two functions: 1) to absorb the energy motor releases power supply in order to stabilize supply voltage and prevent circuit from being broken down due to overvoltage; 2) At the moment that motor starts or switches over rapidly from forward rotation to backward rotation or vice versa, motor needs momentary high current in order to start quickly. Due to the battery response speed and the longer connection wire, momentary high current is usually not immediately obtainable. At this time, it is necessary to rely on energy storage capacitor near motor drive circuit to release a momentary high current.

According to energy storage performance of capacitor, the greater capacitance is, the smaller voltage fluctuates in the same period of time. Therefore, in the use of high-voltage, high-current, the recommendation is made that capacitance C1 be taken as 220uF. Capacitance should be chosen based on concrete applications. Capacitance C1, however, takes at least 10uF.

3、 Static Protection

Input/output port of circuit uses CMOS device, and is sensitive to static discharge. Although TX861 is designed with static discharge protection circuit, measures of TX861 static discharge protection should be taken in the course of transportation, packaging, processing, and storage, especially in processing.

4、 Output-to-ground short circuit, output short circuit

If high-level output and ground, in normal operational condition of circuit, are short-circuited, or if two terminals OUTA and OUTB are short-circuited, then the very high current will flow through the circuit, the very high power dissipation will occur, and the on-chip thermal shut down circuit will be triggered, thus protecting the circuit from burning immediately. However, as the overheating protection circuit only checks temperature, but not the transient current flowing through circuit, the current at output-to-ground short-circuits would be very high, resulting easily in circuit damage. So output-to-ground short-circuit should be avoided in the use of TX861. In test, taking measures of limiting current could avoid similar damage.

5、 Output-to-power supply short-circuit

If low-level output and power supply, in normal operational condition of circuit, are short-circuited, then TX861 will damage.

6、 Blocked Motor

After load motor of drive circuit is blocked in normal operational condition, drive circuit will get into overheating protection mode to prevent circuit from damaging if blocked current exceeds maximum continuous current of drive circuit. If blocked current is much greater than maximum peak current, however, then circuit would damage easily.

7、 Peak current much greater than rated value

If operating voltage of the circuit is close to or greater than maximum operating voltage, and if peak current is much greater than absolute maximum peak current, then chip would burn down as well.



Package Information
ESOP8 Outline Dimensions

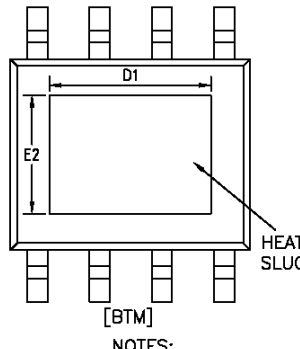
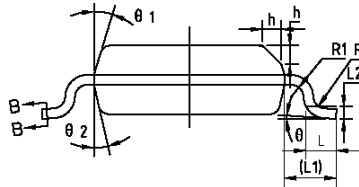
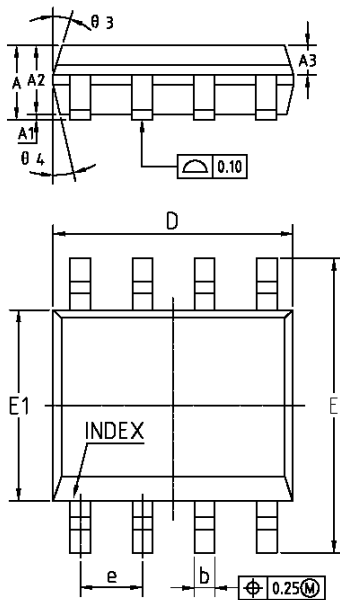

SYMBOL	MIN	NOM	MAX
A	1.35	1.55	1.75
A1	0	0.10	0.15
A2	1.25	1.40	1.65
A3	0.50	0.60	0.70
b	0.38	-	0.51
b1	0.37	0.42	0.47
c	0.17	-	0.25
e1	0.17	0.20	0.23
D	4.80	4.90	5.00
D1	3.10	3.30	3.50
E	5.80	6.00	6.20
E1	3.80	3.90	4.00
E2	2.20	2.40	2.60
e	1.27BSC		
L	0.45	0.60	0.80
L1	1.04REF		
L2	0.25BSC		
R	0.07	-	-
R1	0.07	-	-
h	0.30	0.40	0.50
theta	0	-	8°
theta 1	15°	17°	19°
theta 2	11°	13°	15°
theta 3	15°	17°	19°
theta 4	11°	13°	15°

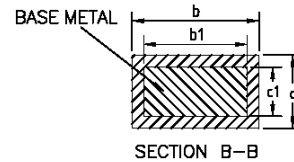

NOTES:
ALL DIMENSIONS REFER TO JEDEC STANDARD MS-012 AA
DO NOT INCLUDE MOLD FLASH OR PROTRUSIONS.

Symbol	Dimension (mm)			Symbol	Dimension (mm)		
	MIN	NOM	MAX		MIN	NOM	MAX
A	-	-	1.77	D	4.7	4.9	5.1
A1	0.08	0.18	0.28	E	5.8	6	6.2
A2	1.2	1.4	1.6	E1	3.7	3.9	4.1
A3	0.55	0.65	0.75	e	1.27BSC		
b	0.39	-	0.48	L	0.5	0.65	0.8
b1	0.38	0.41	0.43	L1	1.05BSC		
c	0.21	-	0.26	theta	0	-	8°
D1	3.1	3.3	3.5	E2	2.2	2.4	2.6



© Shanghai TX Electronics Sci-Tech Co., Ltd

TX cannot assume responsibility for use of any circuitry other than circuitry entirely embodied in a TX product. No circuit patent license, copyrights or other intellectual property rights are implied. TX reserves the right to make changes to their products or specifications without notice. Customers are advised to obtain the latest version of relevant information to verify, before placing orders, that information being relied on is current and complete.