



<http://www.txsemi.com>

TX6202 Series

150mA Low Power LDO

Features

- Low voltage drop: 0.26V@100mA
- High input voltage: 15V
- Low temperature coefficient
- Large Output Current: >0.5A
- Low Quiescent Current: 2.0uA
- Output voltage accuracy: tolerance $\pm 2\%$
- Built-in current limiter
- SOT89 and SOT23-3 package

Applications

- Battery-powered equipment
- Hand-Hold Equipment
- GRS Receivers
- Wireless LAN

General Description

The TX6202 series is a group of positive voltage output, three-pin regulators, that provide a high current even when the input/output voltage differential is small. Low power consumption and high accuracy is achieved through CMOS and laser trimming technologies.

The TX6202 consists of a high-precision voltage reference, an error amplification circuit, and a current limited output driver. Transient response to load variations have improved in comparison to the existing series. SOT89 and SOT23-3 packages are available.

Selection Table

Part No.	Output Voltage	Package	Marking
TX6202P252M	2.5V	SOT89 SOT23-3	24TX
TX6202P282M	2.8V		24XX
TX6202P302M	3.0V		24ZX
TX6202P332M	3.3V		252X
TX6202P362M	3.6V		255X
TX6202P402M	4.0V		259X
TX6202P452M	4.5V		25EX
TX6202P502M	5.0V		25MX



TX6202 Series 150mA Low Power LDO

<http://www.txsemi.com>

Order Information

TX6202P①②③④

Designator	Symbol	Description
①②	Integer	Output Voltage(1.5~5.0V)
③	2	accuracy
④	P	Package:SOT89
	M	Package:SOT23-3

Block Diagram

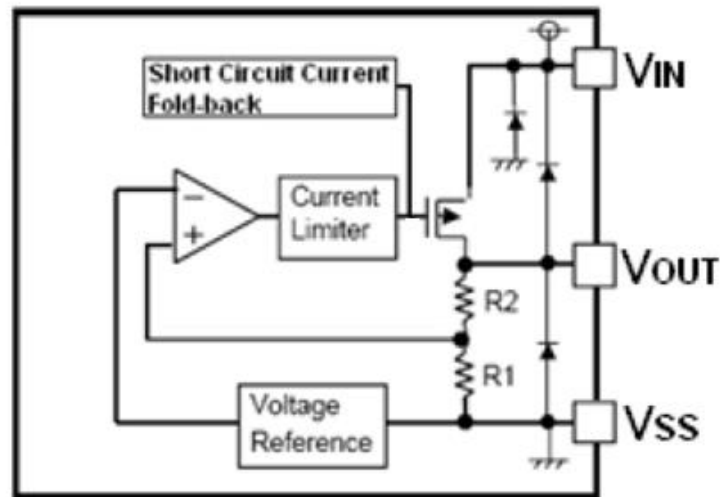

Pin Assignment

SOT89 (Top view)

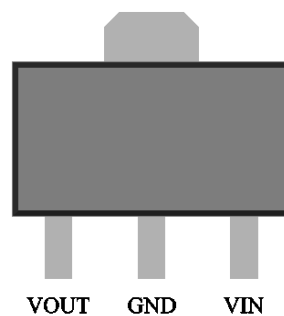

SOT23-3 (Top view)

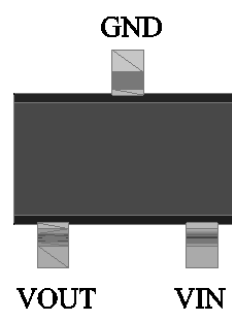



<http://www.txsemi.com>

TX6202 Series 150mA Low Power LDO

Absolute Maximum Ratings

Supply Voltage-0.3V to 15V Storage Temperature-40°C to 125°C
Operating Temperature-40°C to 85°C

Note: These are stress ratings only. Stresses exceeding the range specified under “Absolute Maximum Ratings” may cause substantial damage to the device. Functional operation of this device at other conditions beyond those listed in the specification is not implied and prolonged exposure to extreme conditions may affect device reliability.

Typical Application

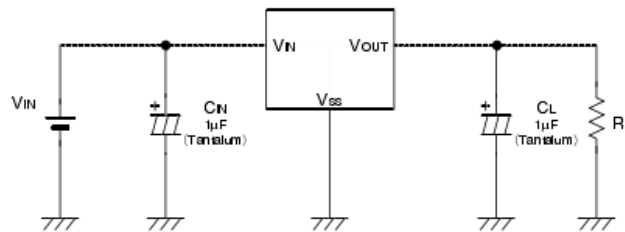

Note1: Input capacitor $C_{IN}=1\mu F$.

Note2: Output capacitor $C_{OUT}=1\mu F/6.8\mu F$ (1µF Tantalum capacitor or 6.8µF ceramic capacitor is recommended).



TX6202 Series

150mA Low Power LDO

<http://www.txsemi.com>

Electrical Characteristics

TX6202 for any output voltage

(Ta=25°C)

Parameter	Symbol	Conditions	Min.	Typ.	Max.	Unit
Output Voltage	Vout	Vin=Vout+1V 1.0mA≤Iout≤30mA	Vout×0.98	--	Vout×1.02	V
Output Current*1	Iout	Vin-Vout=1V	--	150	--	mA
Low dropout*2	Vdrop	Refer to the next table				
Line Regulation	$\frac{\Delta V_{OUT}}{\Delta V_{IN} \times V_{OUT}}$	1.6V≤Vin≤8V Iout=100mA	--	0.05	0.2	%/V
Load Regulation	ΔVout	Vin= Vout+1V 1.0mA≤Iout≤100mA	--	12	30	mV
Output voltage Temperature Coefficient	$\frac{\Delta V_{OUT}}{\Delta Ta}$	Iout=30mA 0°C≤Ta≤70°C	--	±100	--	Ppm/°C
Supply Current	Iss1	--	--	2	--	uA
Input Voltage	Vin	--	--	--	15	V

Electrical Characteristics by Output Voltage:

Output Voltage Vout(V)	Dropout Voltage Vdif (V)		
	Conditions	Typ.	Max.
Vout ≤ 2.0V	Iout=60 mA	0.1	0.12
2.0 < Vout ≤ 3.0	Iout=80 mA	0.12	0.14
3.0 < Vout ≤ 4.0	Iout=100 mA	0.16	0.18
4.0 < Vout ≤ 5.0		0.17	0.18



TX6202 Series

150mA Low Power LDO

<http://www.txsemi.com>

Package Information

3-pin SOT89 Outline Dimensions

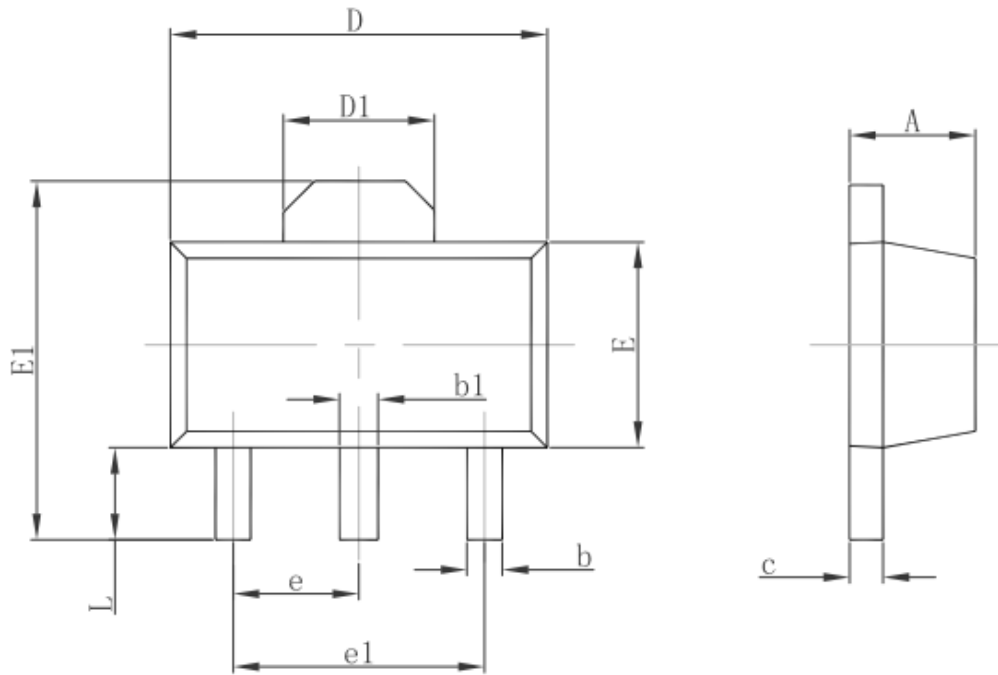

Symbol	Dimensions In Millimeters		Dimensions In Inches	
	Min.	Max.	Min.	Max.
A	1.400	1.600	0.055	0.063
b	0.320	0.520	0.013	0.020
b1	0.400	0.580	0.016	0.023
c	0.350	0.440	0.014	0.017
D	4.400	4.600	0.173	0.181
D1	1.550 REF.		0.061 REF.	
E	2.300	2.600	0.091	0.102
E1	3.940	4.250	0.155	0.167
e	1.500 TYP.		0.060 TYP.	
e1	3.000 TYP.		0.118 TYP.	
L	0.900	1.200	0.035	0.047



TX6202 Series

150mA Low Power LDO

<http://www.txsemi.com>

3-pin SOT23-3 Outline Dimensions

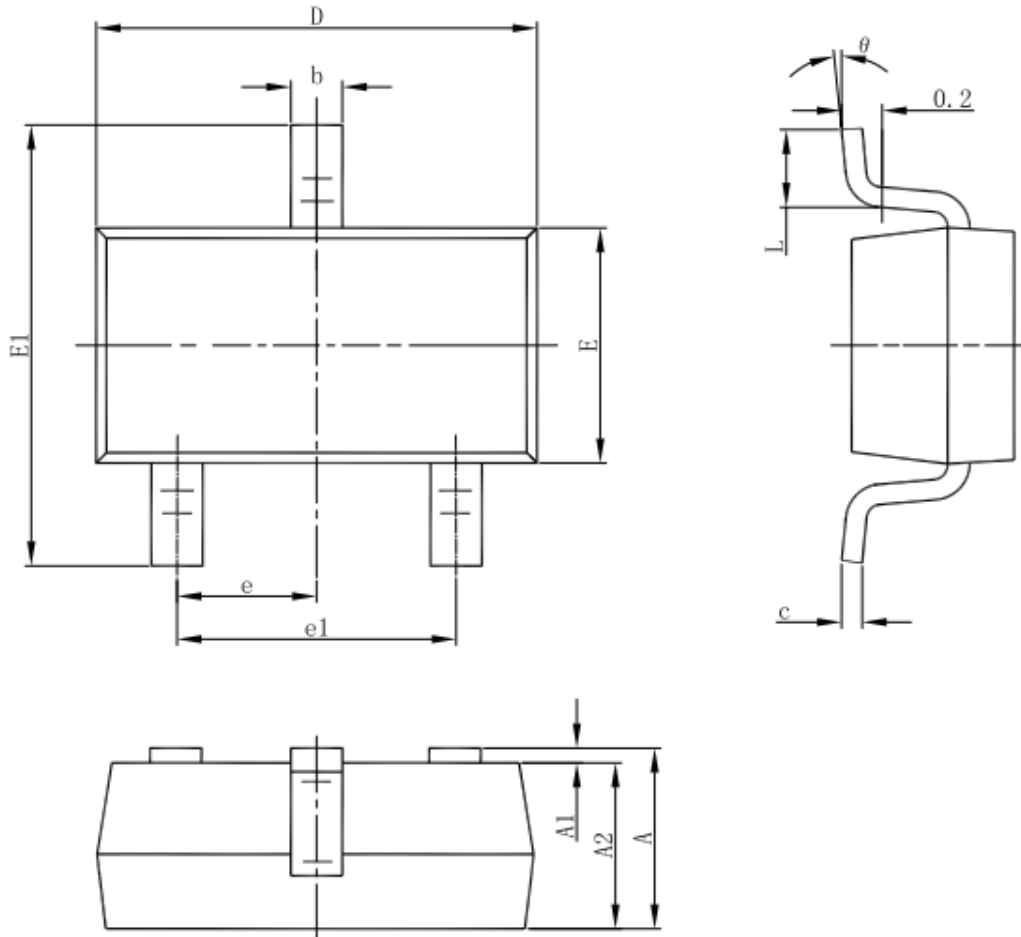

Symbol	Dimensions In Millimeters		Dimensions In Inches	
	Min	Max	Min	Max
A	1.050	1.250	0.041	0.049
A1	0.000	0.100	0.000	0.004
A2	1.050	1.150	0.041	0.045
b	0.300	0.500	0.012	0.020
c	0.100	0.200	0.004	0.008
D	2.820	3.020	0.111	0.119
E	1.500	1.700	0.059	0.067
E1	2.650	2.950	0.104	0.116
e	0.950(BSC)		0.037(BSC)	
e1	1.800	2.000	0.071	0.079
L	0.300	0.600	0.012	0.024
θ	0°	8°	0°	8°



<http://www.txsemi.com>

TX6202 Series ***150mA Low Power LDO***

© Shanghai TX Semiconductor Sci.-Tech. Co., Ltd.

TX cannot assume responsibility for use of any circuitry other than circuitry entirely embodied in a TX product. No circuit patent license, copyrights or other intellectual property rights are implied. TX reserves the right to make changes to their products or specifications without notice. Customers are advised to obtain the latest version of relevant information to verify, before placing orders, that information being relied on is current and complete.