

# TL431 Adjustable Precision Shunt Regulations

<http://www.txsemi.com>

## Features

- Programmable Precise Output Voltage from 2.5V to 36V
- Low Temperature Deviation: 5mV Typical
- Low Equivalent Full-range Temperature Coefficient
- Sink Current Capacity from 1mA to 100 mA
- Low Output Noise
- Wide Operating Range of -40 to 125°C
- ROHS/Halogen Free

## Applications

- Charger
- Voltage Adapter
- Switching Power Supply
- Graphic Card
- Precision Voltage Reference

## General Description

The TL431 is a three-terminal adjustable shunt regulator with guaranteed thermal stability over a full operation range. It features sharp turn-on characteristics, low temperature coefficient and low output impedance, which make it ideal substitute for Zener diode in applications such as switching power supply, charger and other adjustable regulators.

The output voltage of TL431 can be set to any value between  $V_{ref}$  (2.495V) and the corresponding maximum cathode voltage (36V).

The TL431 precision reference is offered in two voltage tolerance: 0.5% and 1%.

This IC is available in 4 Packages: SOT-23 and TO92.

## Block Diagram

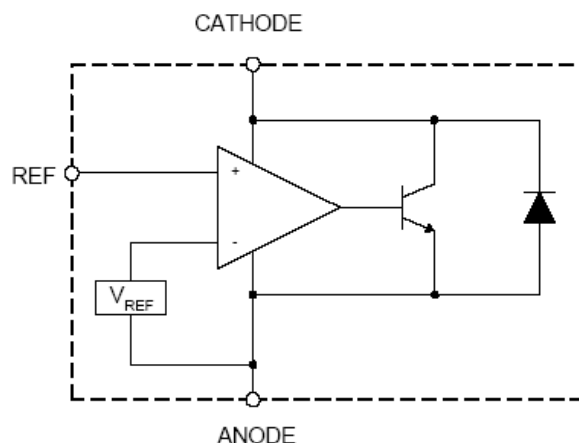

# TL431 Adjustable Precision Shunt Regulations

<http://www.txsemi.com>

## Pin Assignment

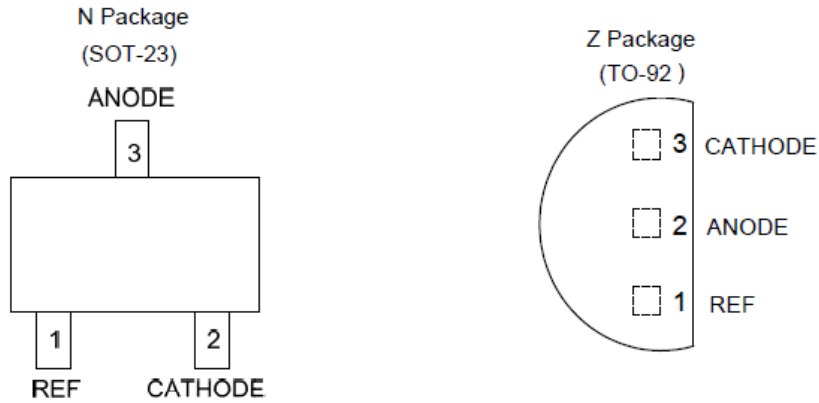

Figure 2. Pin Configuration of TL431

## Absolute Maximum Ratings (Note 5)

Symbol	Parameter	Rating	Unit
$V_{KA}$	Cathode Voltage	40	V
$I_{KA}$	Cathode Current Range (Continuous)	-100 to 150	mA
$I_{REF}$	Reference Input Current Range	10	mA
$P_D$	Power Dissipation	Z, R Package	770
		N, K Package	370
			mW
$T_J$	Junction Temperature	+150	°C
$T_{STG}$	Storage Temperature Range	-65 to +150	°C
ESD	ESD (Human Body Model)	2000	V

Note 5: Stresses greater than those listed under "Absolute Maximum Ratings" may cause permanent damage to the device. These are stress ratings only, and functional operation of the device at these or any other conditions beyond those indicated under "Recommended Operating Conditions" is not implied. Exposure to "Absolute Maximum Ratings" for extended periods may affect device reliability.

## Recommended Operating Conditions

Symbol	Parameter	Min	Max	Unit
$V_{KA}$	Cathode Voltage	$V_{REF}$	36	V
$I_{KA}$	Cathode Current	1.0	100	mA
$T_A$	Operating Ambient Temperature Range	-40	+125	°C

# TL431 Adjustable Precision Shunt Regulations

<http://www.txsemi.com>

## Electrical Characteristics (Operating Conditions: $T_A = +25^\circ\text{C}$ , unless otherwise specified.)

Symbol	Parameter	Test Circuit	Conditions	Min	Typ	Max	Unit	
V <sub>REF</sub>	Reference Voltage	4	V <sub>KA</sub> = V <sub>REF</sub> , I <sub>KA</sub> = 10mA	2.483	2.495	2.507	V	
				2.470	2.495	2.520		
ΔV <sub>REF</sub>	Deviation of Reference Voltage Over Full Temperature Range	4	V <sub>KA</sub> = V <sub>REF</sub> , I <sub>KA</sub> = 10mA	0 to +70°C	–	5	20	mV
				-40 to +85°C	–	5	26	
				-40 to +125°C	–	5	40	
$\frac{\Delta V_{REF}}{\Delta V_{KA}}$	Ratio of Change in Reference Voltage to the Change in Cathode Voltage	5	I <sub>KA</sub> = 10mA	ΔV <sub>KA</sub> = 10V to V <sub>REF</sub>	–	-1.0	-2.7	mV/V
				ΔV <sub>KA</sub> = 36V to 10V	–	-0.5	-2.0	
I <sub>REF</sub>	Reference Current	5	I <sub>KA</sub> = 10mA, R <sub>1</sub> = 10KΩ, R <sub>2</sub> = ∞	–	0.7	4	μA	
ΔI <sub>REF</sub>	Deviation of Reference Current Over Full Temperature Range	5	I <sub>KA</sub> = 10mA, R <sub>1</sub> = 10KΩ, R <sub>2</sub> = ∞, T <sub>A</sub> = -40 to +125°C	–	0.4	1.2	μA	
I <sub>KA</sub> (Min)	Minimum Cathode Current for Regulation	4	V <sub>KA</sub> = V <sub>REF</sub>	–	0.4	1.0	mA	
I <sub>KA</sub> (Off)	Off-state Cathode Current	6	V <sub>KA</sub> = 36V, V <sub>REF</sub> = 0	–	0.5	1.0	μA	
Z <sub>KA</sub>	Dynamic Impedance	4	V <sub>KA</sub> = V <sub>REF</sub> , I <sub>KA</sub> = 1 to 100mA, f ≤ 1.0KHz	–	0.2	0.5	Ω	
θ <sub>JC</sub>	Thermal Resistance	–	SOT-23	–	135.9	–	°C/W	
			TO-92	–	81.9	–		

# TL431 Adjustable Precision Shunt Regulations

<http://www.txsemi.com>

## Typical Applications Circuit

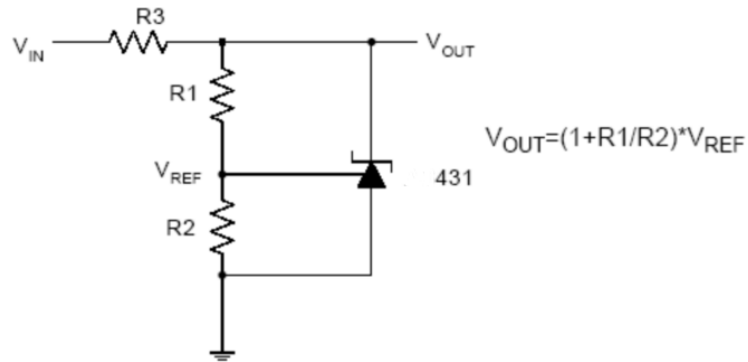

**Shunt Regulator**

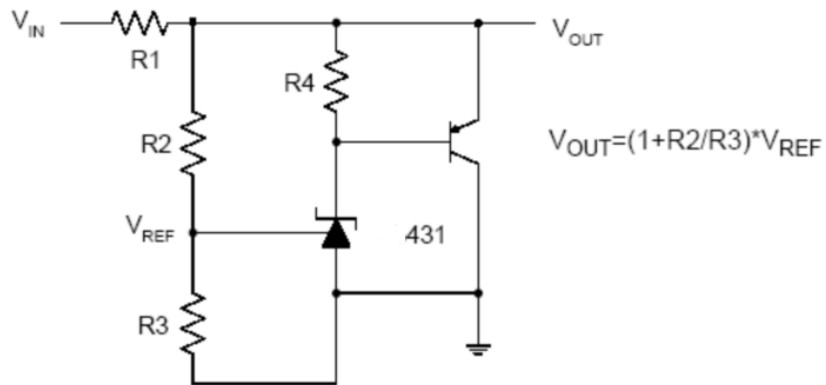

**High Current Shunt Regulator**

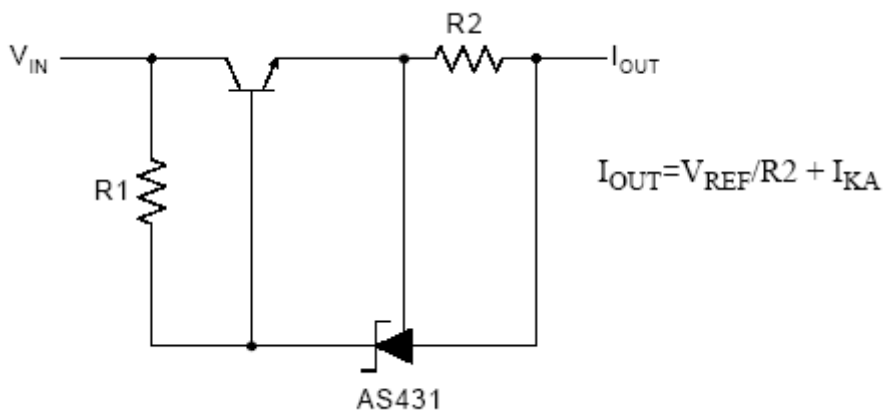

**Current Source or Current Limit**

# TL431 Adjustable Precision Shunt Regulations

<http://www.txsemi.com>

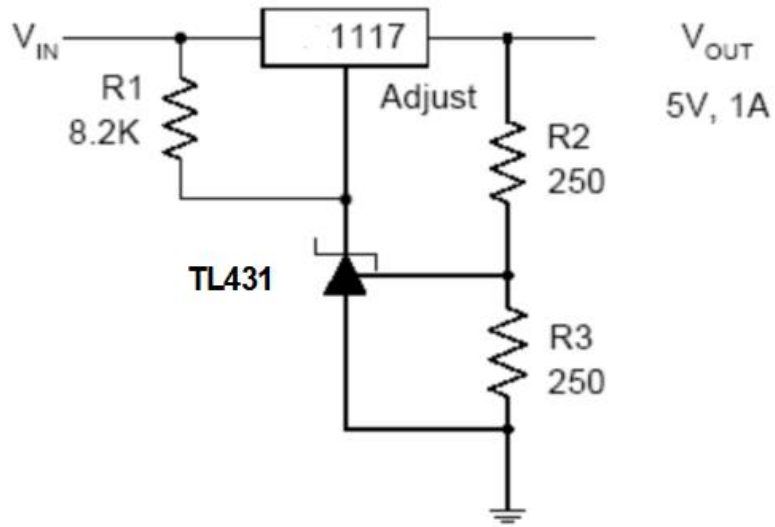

Precision 5V 1A Regulator

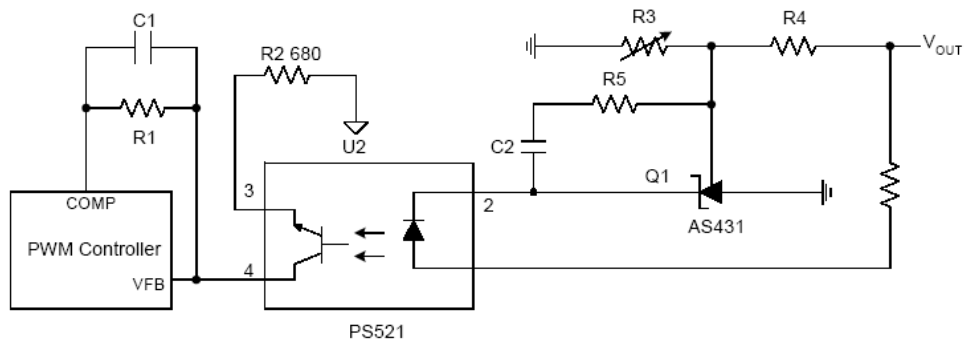

PWM Converter with Reference

# TL431 Adjustable Precision Shunt Regulations

<http://www.txsemi.com>

## Electrical Characteristics (Cont.)

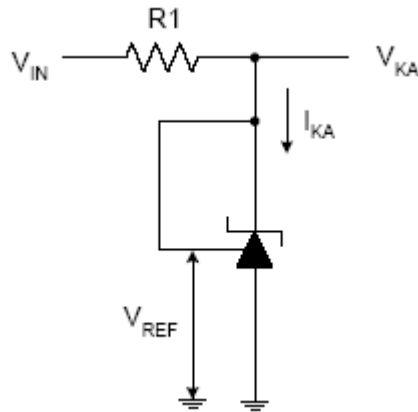

Test Circuit 4 for  $V_{KA} = V_{REF}$

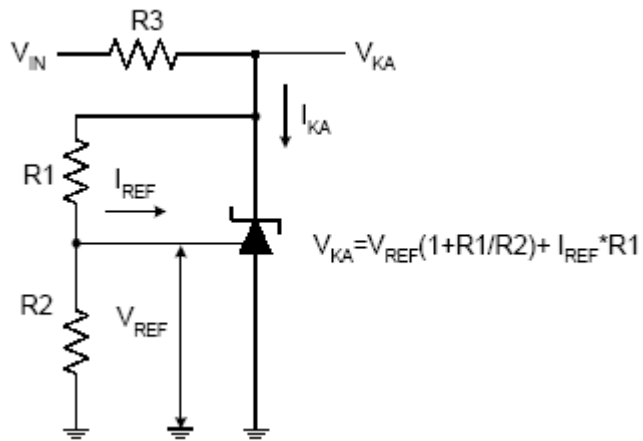

Test Circuit 5 for  $V_{KA} > V_{REF}$

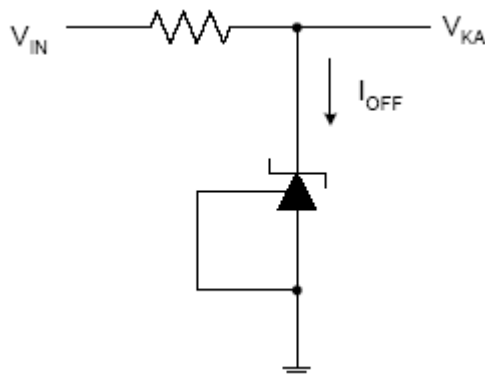

Test Circuit 6 for  $I_{OFF}$

# TL431 Adjustable Precision Shunt Regulations

<http://www.txsemi.com>

## Performance Characteristics

Reference Voltage vs.ambient temperature

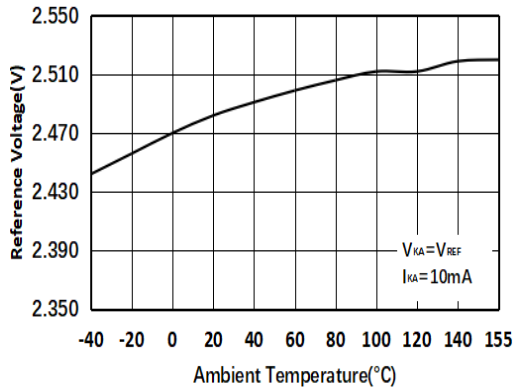

Reference Current vs. Ambient Temperature

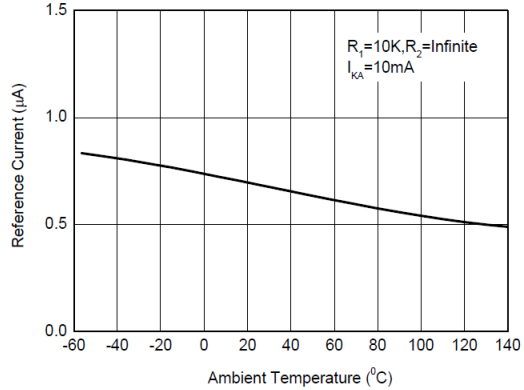

Cathode Current vs. Cathode Voltage

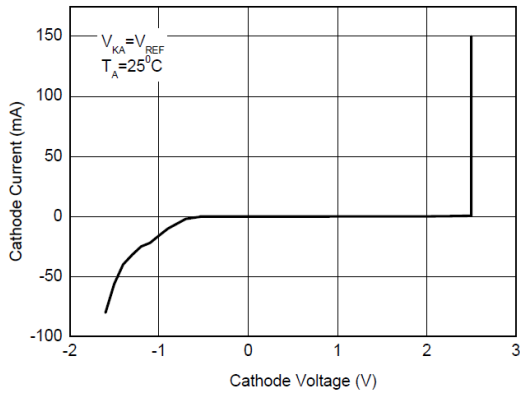

Cathode Current vs. Cathode Voltage

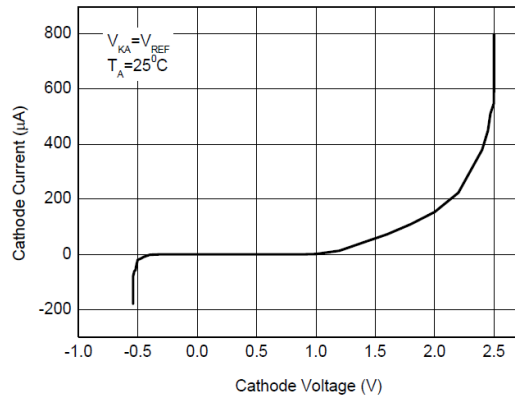

Off-State Cathode Current vs. Ambient Temperature

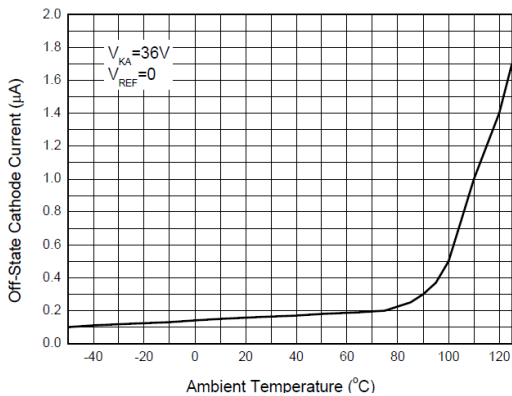

Ratio of Delta Reference Voltage to the Ratio of Delta Cathode Voltage

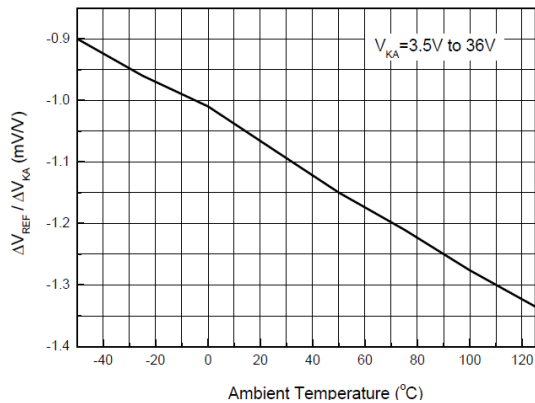

# TL431 Adjustable Precision Shunt Regulations

<http://www.txsemi.com>

## Performance Characteristics (Cont.)

**Small Signal Voltage Gain vs. Frequency**

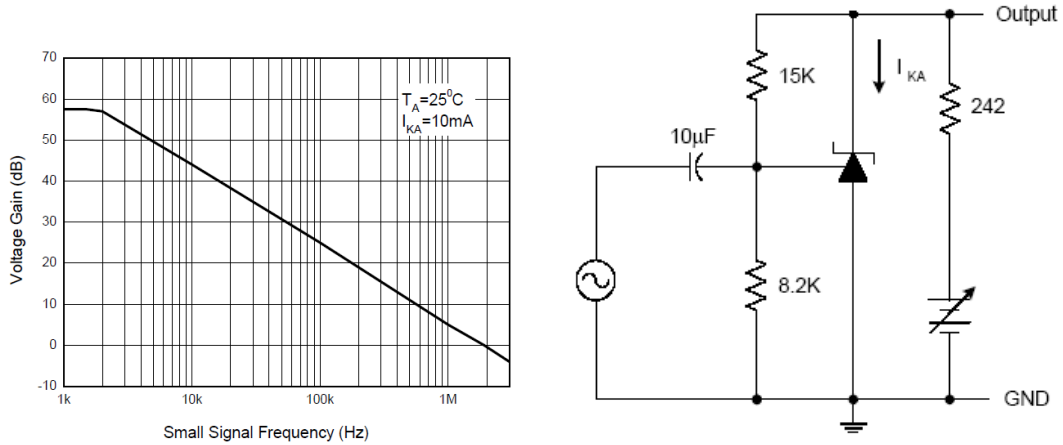

**Reference Impedance vs. Frequency**

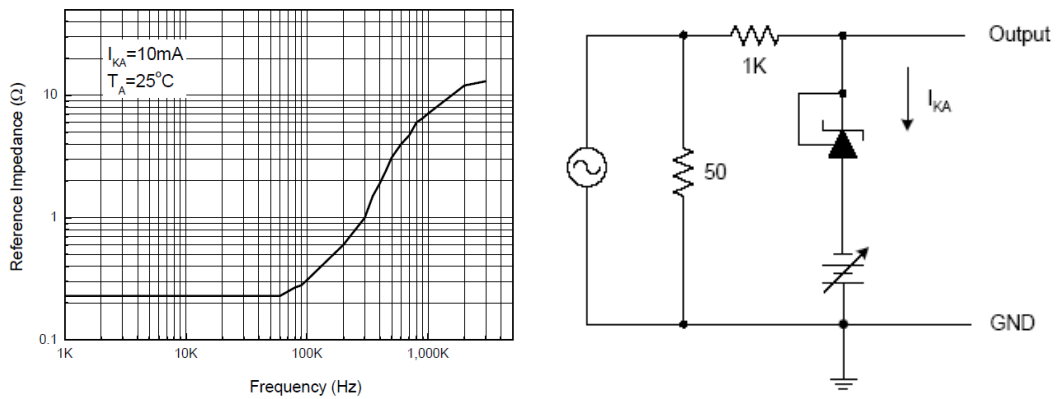

**Stability Boundary Conditions vs. Load Capacitance**

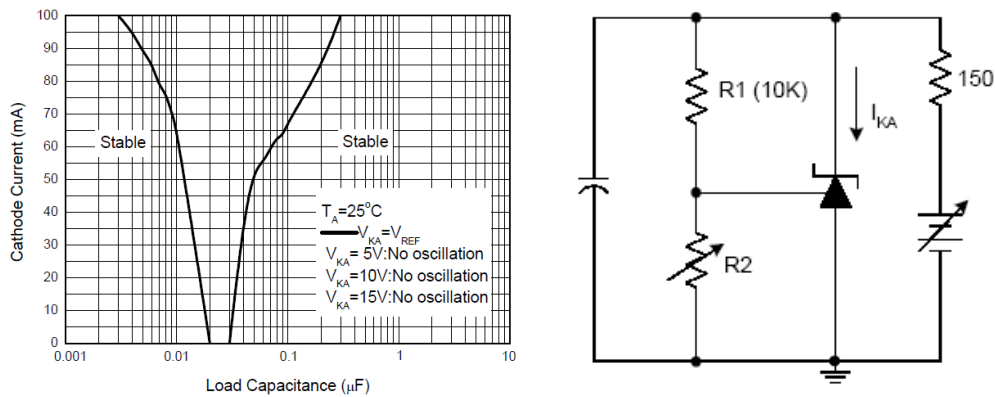



# TL431 Adjustable Precision Shunt Regulations

<http://www.txsemi.com>

## Performance Characteristics (Cont.)

### Pulse Response of Input and Output Voltage

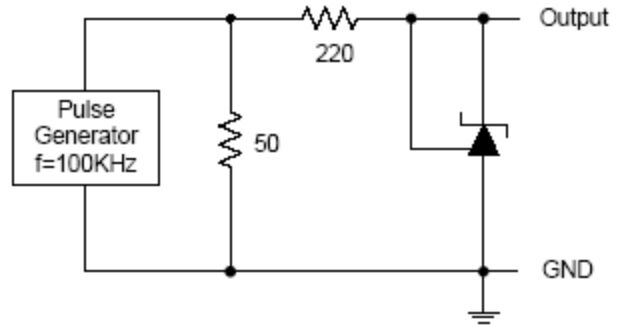
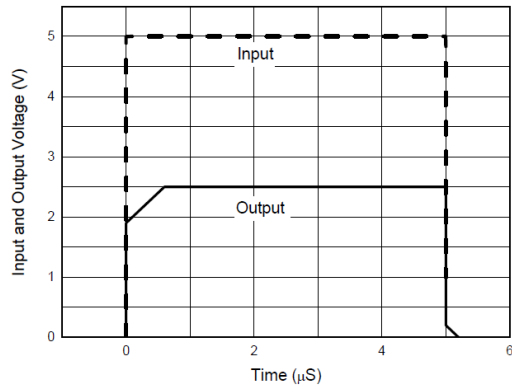

# TL431 Adjustable Precision Shunt Regulations

<http://www.txsemi.com>

## Package Outline Dimensions (All dimensions in mm(inch).)

### TO-92 (Bulk Packing)

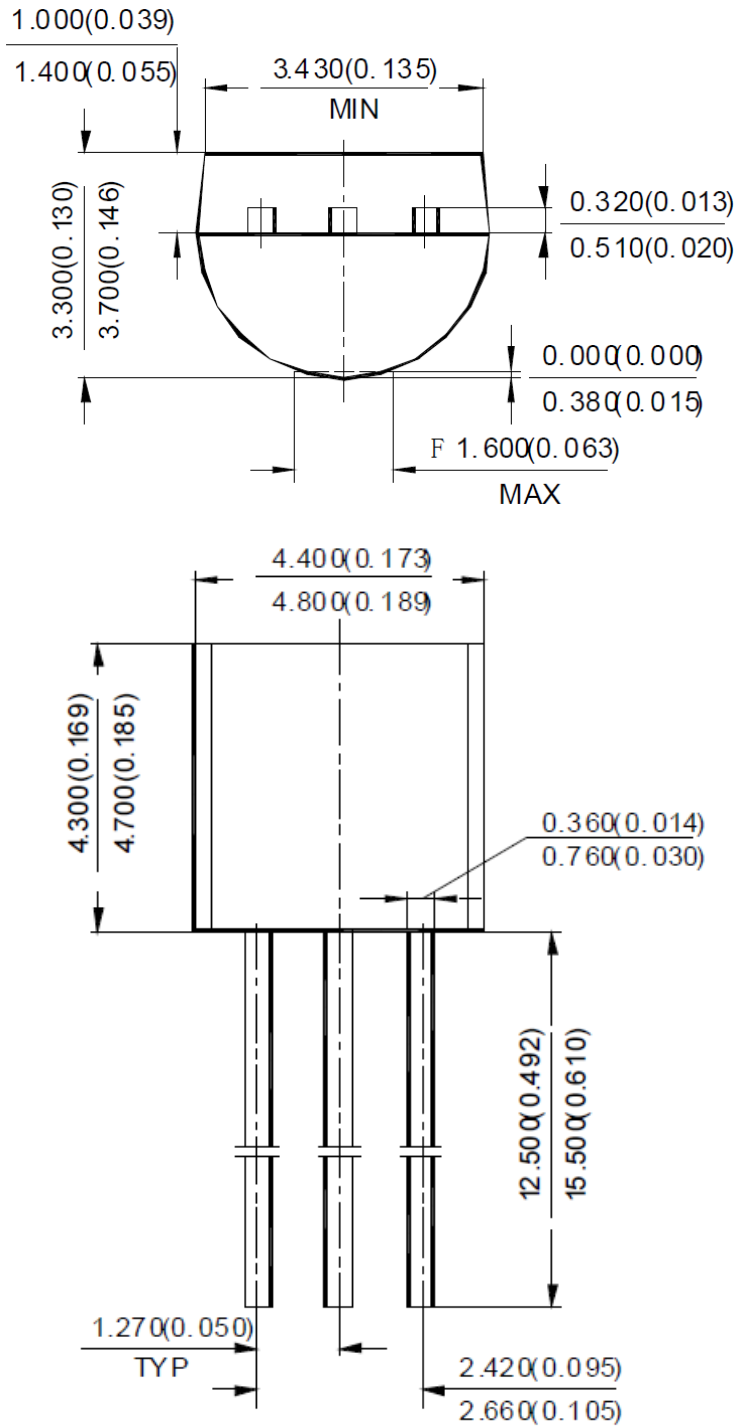

# TL431 Adjustable Precision Shunt Regulations

<http://www.txsemi.com>

## Package Outline Dimensions (Cont. All dimensions in mm(inch).)

### TO-92 (Ammo Packing)

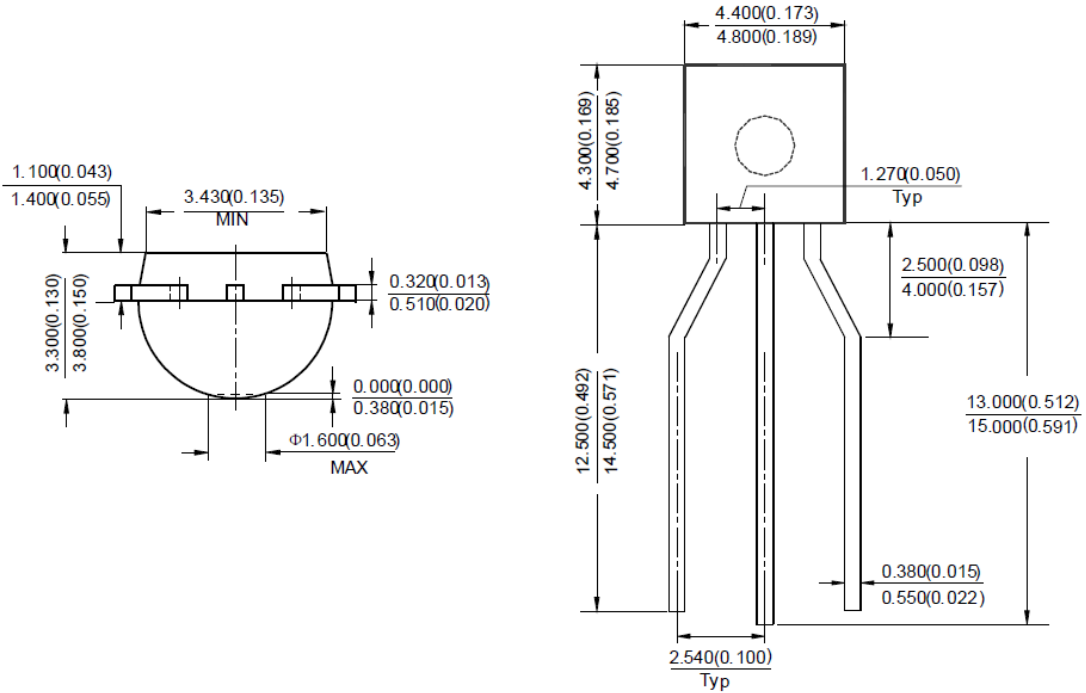

# TL431 Adjustable Precision Shunt Regulations

<http://www.txsemi.com>

## Package Outline Dimensions (Cont. All dimensions in mm(inch).)

### SOT-23

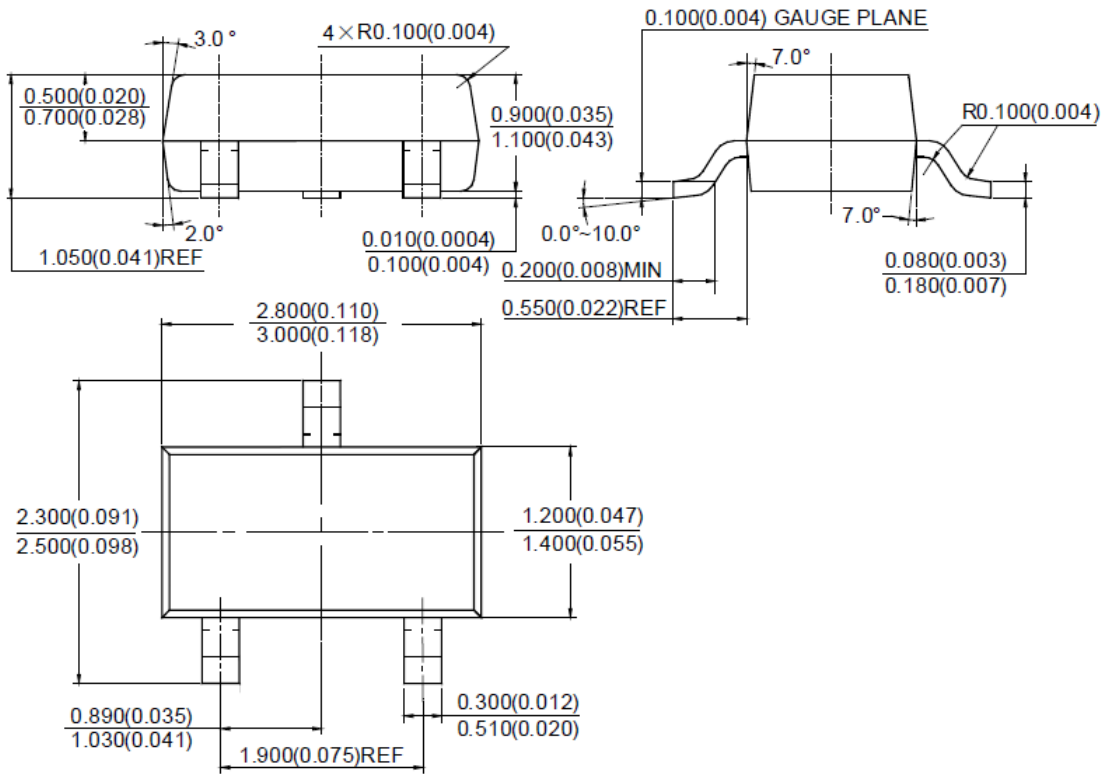

# **TL431    Adjustable Precision Shunt Regulations**

---

<http://www.txsemi.com>

© Shanghai TX Semiconductor Sci.-Tech. Co., Ltd.

TX cannot assume responsibility for use of any circuitry other than circuitry entirely embodied in a TX product. No circuit patent license, copyrights or other intellectual property rights are implied. TX reserves the right to make changes to their products or specifications without notice. Customers are advised to obtain the latest version of relevant information to verify, before placing orders, that information being relied on is current and complete.