



# TX803 series Power Supply Supervisor

## Features

- Low power consumption
- Low temperature coefficient
- Built-in delay circuit: 200ms
- High input voltage (up to 8V)
- Output voltage accuracy: tolerance  $\pm 2\%$
- SOT23 ,SOT23-3 and SOT89 package

## Applications

- Microprocessor reset circuitry
- Memory battery back-up circuits
- Power on reset circuits
- System battery life and charge voltage monitors
- Delay circuitry
- Power failure detection

## General Description

The TX803 series are highly accurate, low power consumption voltage detectors, manufactured using CMOS and laser trimming technologies. A delay circuit is built-in to each detectors. Detect voltage is extremely accurate with minimal

temperature drift. N-ch open drain output configurations is available. Since the delay circuit is built-in, peripherals are unnecessary and high density mounting is possible.

## Selection Table

Part No	Detectable Voltage	Delay Time	Tolerance	Package
TX803-xxxXX	4.63V	200ms	$\pm 2\%$	SOT23 SOT23-3 SOT89
TX803-xxxXX	4.38V		$\pm 2\%$	
TX803-xxxXX	4.00V		$\pm 2\%$	
TX803-xxxXX	3.08V		$\pm 2\%$	
TX803-xxxXX	2.93V		$\pm 2\%$	
TX803-xxxXX	2.63V		$\pm 2\%$	

Note: "xxx" stands for detectable voltages. "XX" stands for package.

## Order Information

TX803-①②③④⑤

Designator	Symbol	Description
①②③	xxx	Detect voltage
④	N	Package:SOT23
	M	Package:SOT23-3
	P	Package:SOT89
⑤	R	RoHS / Pb Free
	G	Halogen Free



## Block Diagram

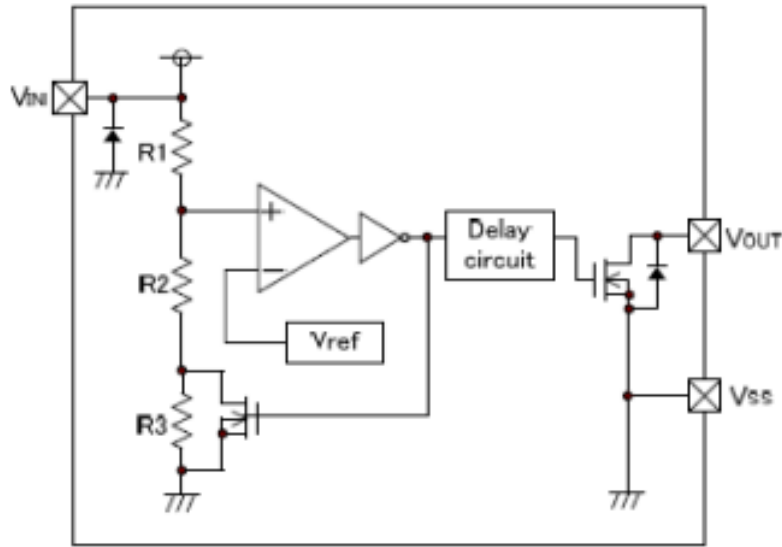

## Marking Rule

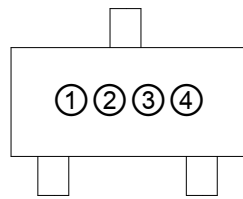

SOT23/SOT23-3(TOP VIEW)

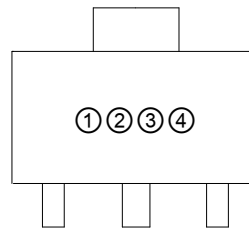

SOT89 (TOP VIEW)

Product	Mark
TX803-263	BFAA
TX803-293	BDAA
TX803-308	BCAA
TX803-400	BWAA
TX803-438	BBAA

## Product Information

Product	Package	MOQ
TX803	SOT23	3000PCS
TX803	SOT23-3	3000PCS
TX803	SOT89	1000PCS



# TX803 series Power Supply Supervisor

## Pin Assignment

### SOT23/SOT23-3(TOP VIEW)

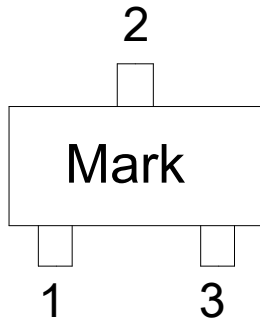

Table1 : TX803 series (SOT23/SOT23-3 PKG)

PIN NO.	PIN NAME	FUNCTION
1	GND	GND pin
2	VIN	Input voltage pin
3	Reset	Reset pin

### SOT89 (TOP VIEW)

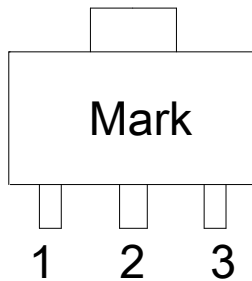

Table2 : TX803 series (SOT89 PKG)

PIN NO.	PIN NAME	FUNCTION
1	GND	GND pin
2	VIN	Input voltage pin
3	Reset	Reset pin

## Absolute Maximum Ratings

Input Voltage .....-0.3V to 8.0V

Storage Temperature .....-40°C to 125°C

Operating Temperature .....-30°C to 80°C

Note: These are stress ratings only. Stresses exceeding the range specified under “Absolute Maximum Ratings” may cause substantial damage to the device. Functional operation of this device at other conditions beyond those listed in the specification is not implied and prolonged exposure to extreme conditions may affect device reliability.

## Thermal Information

Symbol	Parameter	Package	Max.	Unit
$\theta_{JA}$	Thermal Resistance (Junction to Ambient) (Assume no ambient airflow, no heat sink)	SOT23-3	250	°C/W
		SOT89	500	°C/W
$P_D$	Power Dissipation	SOT23-3	0.20	W
		SOT89	0.50	W

Note:  $P_D$  is measured at  $T_a = 25^\circ\text{C}$



<http://www.txsemi.com>

## TX803 series Power Supply Supervisor

### Electrical Characteristics

Symbol	Parameter	Test Conditions	Min.	Typ.	Max.	Unit
V <sub>CC</sub>	Input Voltage (V <sub>CC</sub> ) Range	25°C	1.2		7.5	V
I <sub>SS</sub>	Supply Current	V <sub>IN</sub> =6V, V <sub>det</sub> =2.63V	1	1.8	2.5	μA
V <sub>DET</sub>	Reset Threshold	TA=25°C	4.56	4.63	4.70	V
		TA=25°C	4.31	4.38	4.45	
		TA=25°C	3.93	4.00	4.06	
		TA=25°C	3.04	3.08	3.11	
		TA=25°C	2.89	2.93	2.96	
		TA=25°C	2.59	2.63	2.66	
	Reset Threshold Stability			30		Ppm/°C
	V <sub>CC</sub> to Reset Delay	V <sub>CC</sub> = V <sub>TH</sub> to V <sub>TH</sub> -100mV		20		us
V <sub>OL</sub>	Reset Active Timeout Period		100	200	300	ms



# TX803 series Power Supply Supervisor

## Timing Chart

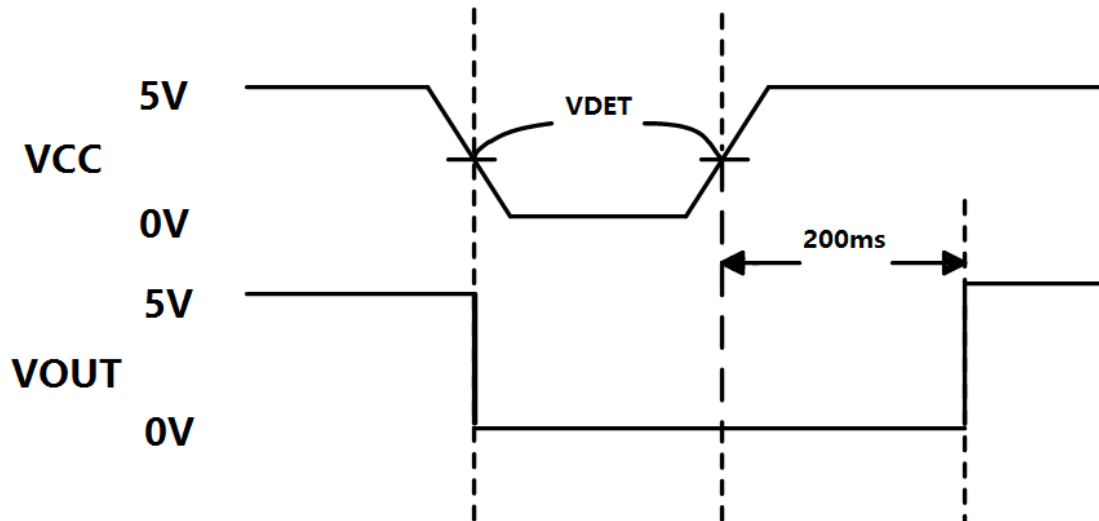

## Application Circuits

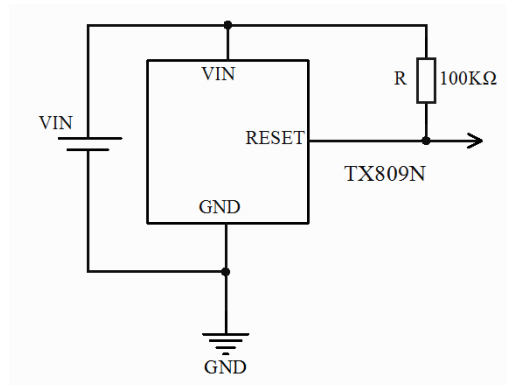



<http://www.txsemi.com>

# TX803 series Power Supply Supervisor

## Package Information 3-pin SOT23 Outline Dimensions

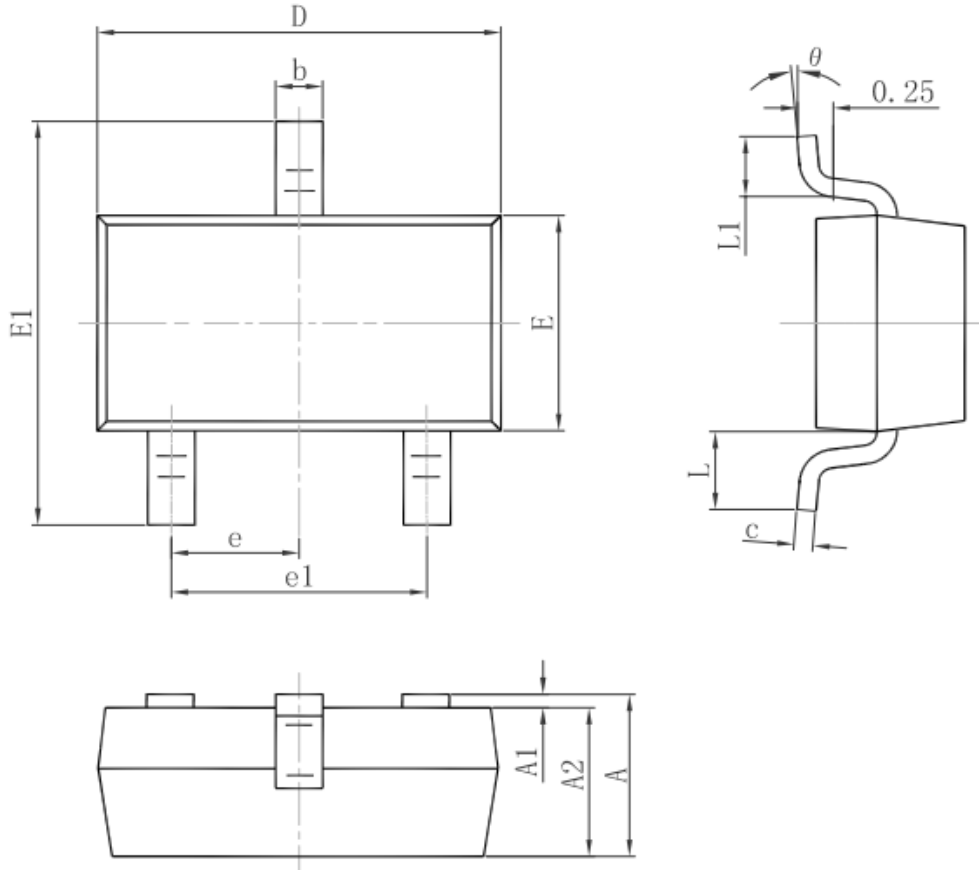

Symbol	Dimensions In Millimeters		Dimensions In Inches	
	Min.	Max.	Min.	Max.
A	0.900	1.150	0.035	0.045
A1	0.000	0.100	0.000	0.004
A2	0.900	1.050	0.035	0.041
b	0.300	0.500	0.012	0.020
c	0.080	0.150	0.003	0.006
D	2.800	3.000	0.110	0.118
E	1.200	1.400	0.047	0.055
E1	2.250	2.550	0.089	0.100
e	0.950 TYP.		0.037 TYP.	
e1	1.800	2.000	0.071	0.079
L	0.550 REF.		0.022 REF.	
L1	0.300	0.500	0.012	0.020
$\theta$	0°	8°	0°	8°



<http://www.txsemi.com>

# TX803 series Power Supply Supervisor

## 3-pin SOT89 Outline Dimensions

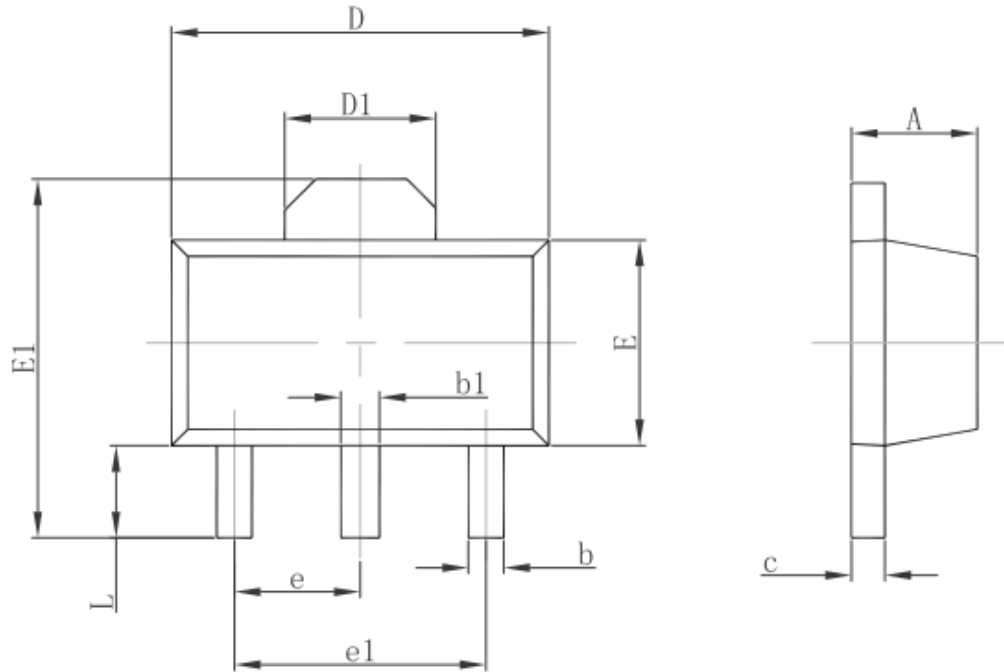

Symbol	Dimensions In Millimeters		Dimensions In Inches	
	Min.	Max.	Min.	Max.
A	1.400	1.600	0.055	0.063
b	0.320	0.520	0.013	0.020
b1	0.400	0.580	0.016	0.023
c	0.350	0.440	0.014	0.017
D	4.400	4.600	0.173	0.181
D1	1.550 REF.		0.061 REF.	
E	2.300	2.600	0.091	0.102
E1	3.940	4.250	0.155	0.167
e	1.500 TYP.		0.060 TYP.	
e1	3.000 TYP.		0.118 TYP.	
L	0.900	1.200	0.035	0.047



# TX803 series Power Supply Supervisor

## 3-pin SOT23-3 Outline Dimensions

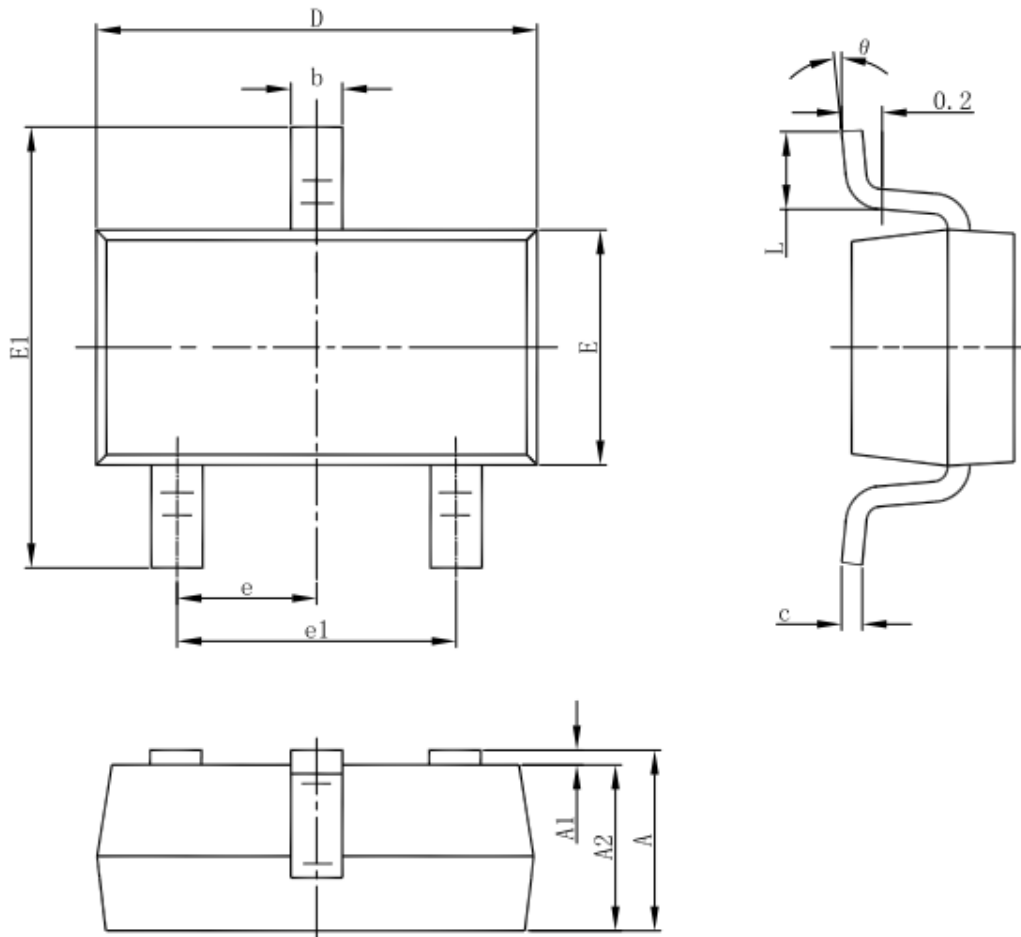

Symbol	Dimensions In Millimeters		Dimensions In Inches	
	Min	Max	Min	Max
A	1.050	1.250	0.041	0.049
A1	0.000	0.100	0.000	0.004
A2	1.050	1.150	0.041	0.045
b	0.300	0.500	0.012	0.020
c	0.100	0.200	0.004	0.008
D	2.820	3.020	0.111	0.119
E	1.500	1.700	0.059	0.067
E1	2.650	2.950	0.104	0.116
e	0.950(BSC)		0.037(BSC)	
e1	1.800	2.000	0.071	0.079
L	0.300	0.600	0.012	0.024
theta	0°	8°	0°	8°





<http://www.txsemi.com>

## ***TX803 series*** ***Power Supply Supervisor***

---

© Shanghai TX Semiconductor Sci.-Tech. Co., Ltd.

TX cannot assume responsibility for use of any circuitry other than circuitry entirely embodied in a TX product. No circuit patent license, copyrights or other intellectual property rights are implied. TX reserves the right to make changes to their products or specifications without notice. Customers are advised to obtain the latest version of relevant information to verify, before placing orders, that information being relied on is current and complete.